

NASA TECH BRIEF

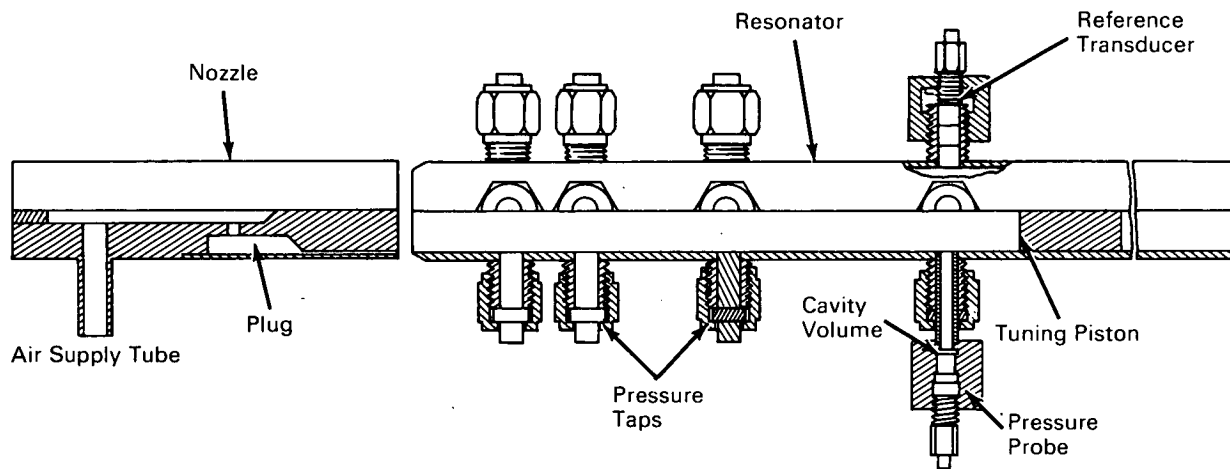

NASA Tech Briefs announce new technology derived from the U.S. space program. They are issued to encourage commercial application. Tech Briefs are available on a subscription basis from the Clearinghouse for Federal Scientific and Technical Information, Springfield, Virginia 22151. Requests for individual copies or questions relating to the Tech Brief program may be directed to the Technology Utilization Division, NASA, Code UT, Washington, D.C. 20546.

Sinusoidal-Pressure Generator for Testing Dynamic Pressure Probes



Schematic Diagram of Pressure Generator

A simple sinusoidal-pressure generator (see fig.) measures the frequency response of small pressure-measuring probes. It can produce sinusoidal pressures at frequencies from 300 to 5000 Hz and peak-to-peak amplitudes up to 5.6 lb/in². The design is based on the Galton tube, a resonant tube driven by an annular air jet (organ-pipe principle). Both amplitude and phase-angle measurements are made for test pressure probes at various frequencies; these data are compared with measurements from a small piezoelectric transducer mounted flush with the tube's wall. The generator may also find use in testing of fluidic devices for frequency response.

Measurement of the frequency response of pressure probes has generally been limited to frequencies lower than a few hundred Hertz. Periodic pressure signals have been generated with rotating valves and flow modulators, siren-tuned cavities, and piston-driven devices which, however, are generally large, com-

plicated, and expensive and do not produce clean sinusoidal-pressure waves at high frequencies as does the new generator. A clean sinusoidal-pressure wave shape is a primary requisite for determination of the response of probes unless harmonic analysis of the measured signals is undertaken. There are various techniques for such analyses, but there is considerable complexity in both performance of the analysis and reduction of the recorded transient signal to a form suitable for analysis.

The resonator (see fig.) is made of a 12-in. length of tubing 1-in. in outer diameter and 0.065-in. in wall thickness. The open end of the tube is tapered at 30° relative to the tube's axis to effect a sharp edge. The resonant frequency is adjusted by movement of the tuning piston. The nozzle is made of tubing of the same diameter as that used in the resonator; a plug fitted within the tube is machined so as to provide an annular passage for air flow; the annulus is 0.03-in.

(continued overleaf)

thick. Both the position of the tuning piston and the nozzle-to-resonator spacings are varied by electric motors.

In operation, air flows through the nozzle and impinges on the sharp edge of the resonator. The resultant turbulence causes the air column within the resonator to oscillate, generating a standing wave in the resonator tube. Depending on supply pressure and nozzle-to-resonator spacing, either quarter-wave length modes or odd multiples of the quarter-wave length mode can be stably maintained in the resonator. Wave-shape distortion is no greater than 3% at high pressures; less than 1% at 0.7 lb/in² peak to peak.

Four sets of pressure ports, each consisting of three ports, are located along the resonator tube; ports at more than one axial position are required for coverage of the frequency range. A pressure node is always located at the nozzle end; a pressure antinode, at the piston end. As the oscillation mode changes, other pressure nodes and antinodes appear within the resonator tube; thus the position of the four sets of pressure-measuring ports is dictated by the requirement that a set of ports be available in the vicinity of an antinode for any frequency and oscillatory mode used. The axial positions of the four sets of ports were determined so that, with the generator operating in the first mode, a pressure tap is available where the pressure is within 75% of maximum. One of the three ports at each axial station is for the test probe, one is for the reference transducer, and the third is a spare.

Notes:

1. This information may interest persons concerned with design, manufacture, and use of instruments, especially for measurement of pressure.
2. The following documentation may be obtained from:

Clearinghouse for Federal Scientific
and Technical Information
Springfield, Virginia 22151
Single document price \$3.00
(or microfiche \$0.65)

Reference:

NASA-TM-X-1981 (N70-23106), A System for Testing Dynamic Pressure Probes Utilizing a Sinusoidal Pressure Generator

3. Technical questions may be directed to:
Technology Utilization Officer
Lewis Research Center
21000 Brookpark Road
Cleveland, Ohio 44135
Reference: B70-10352

Patent status:

No patent action is contemplated by NASA.

Source: T.W. Myland, V.D. Gebben, and
Dr. R. Englund, Jr.
Lewis Research Center
(LEW-11094)