

NASA TECH BRIEF



NASA Tech Briefs are issued to summarize specific innovations derived from the U.S. space program, to encourage their commercial application. Copies are available to the public at 15 cents each from the Clearinghouse for Federal Scientific and Technical Information, Springfield, Virginia 22151.

Signal Conditioner Circuit for Photomultiplier Tube

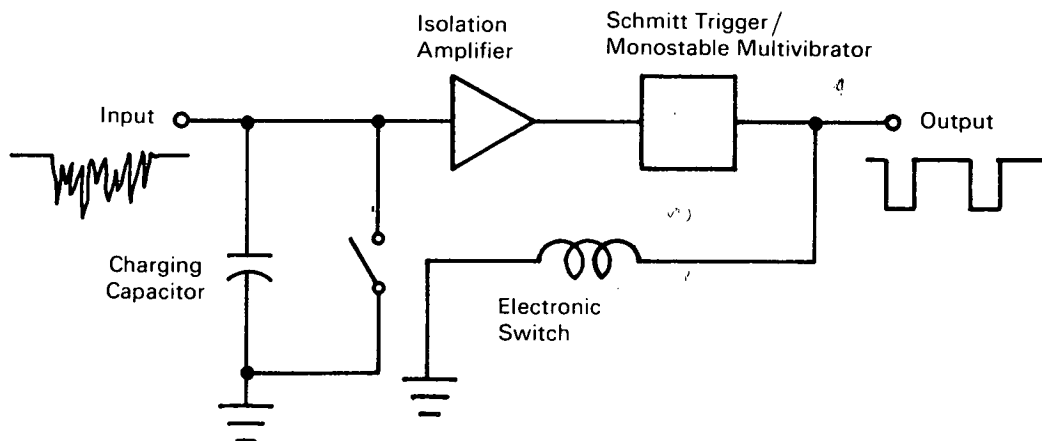

Figure 1. Block Diagram of Signal Conditioner Circuit.

The use of a photomultiplier tube to measure the total radiation dose absorbed in a scintillation crystal has commonly been performed by pulse-height analysis. In this technique a multichannel voltage discriminator sorts the phototube output pulses into specific amplitude increments, and counts the pulses that occur at each amplitude for a specified period. The result is a pulse-count rate vs amplitude spectrum that is readily adaptable to integration by numerical methods, with an accuracy essentially proportional to the number of available channels.

The simple, miniaturized circuit shown in Figure 1 and a detailed diagram of it in Figure 2 can significantly improve the measurement of the total radiation dose absorbed. The input is connected directly to the anode of a photomultiplier tube that is optically coupled to a scintillation crystal. The current from the anode is accumulated in the charging capacitor until the voltage caused by the charge reaches the trip-point of the Schmitt Trigger (ST),

as translated through the isolation amplifier. The ST has a monostable-multivibrator feature that simultaneously supplies an output pulse and a trigger to close the shorting switch around the charging capacitor. The capacitor discharges during the period corresponding to the output pulse width, and then begins to recharge as the trailing edge of the output pulse opens the short circuit. The cycle is then repeated, resulting in an output pulse rate proportional to the current from the phototube.

The total number of pulses from the circuit during a specific time is a measure of the total charge applied to the charging capacitor during this time. Since the charge per unit time, or current, from the scintillation detector anode is proportional to the energy deposited in the scintillation crystal, the pulse count represents the total dose.

A unique feature of the circuit is that the temperature coefficient of the field-effect transistor gate-source voltage in the isolation amplifier can be

(continued overleaf)

readily controlled. This coefficient has been determined to be a function of the drain current.

The signal conditioner circuit is essentially a miniature charge-measuring circuit with a pulse frequency readout. Thus, it can also measure a charge supplied in current waveforms that vary randomly in amplitude, frequency, and width, such as provided by photomultiplier tubes in pulse applications. For example, it is considerably better than the ammeter for measuring such a current.

Notes:

1. This invention may be of interest to the manufacturers of electronic equipment.

2. No additional documentation is available. Specific questions, however, may be directed to:

Technology Utilization Officer
Langley Research Center
Hampton, Virginia 23365
Reference: B70-10096

Patent status:

No patent action is contemplated by NASA.

Source: Alfred Cellier and Wayne M. Hoover of
Texas Instruments Incorporated
Subcontractor to The Boeing Company
under contract to
Langley Research Center
(XLA-10773)

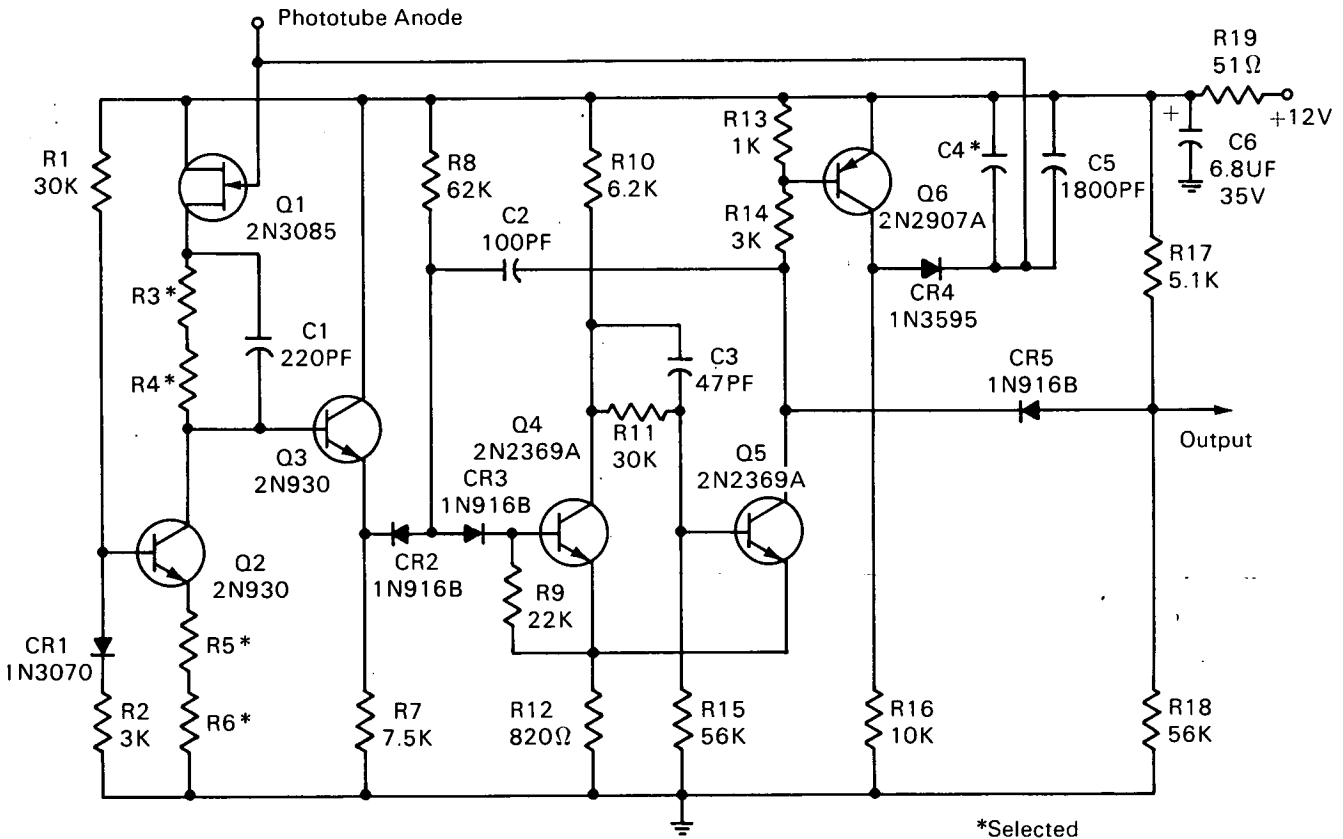

Figure 2. Detailed diagram of the signal conditioner circuit.