

August 1970

Brief 70-10041

NASA TECH BRIEF



NASA TechBriefs announce new technology derived from the U.S. space program. They are issued to encourage commercial application. Tech Briefs are available on a subscription basis from the Clearinghouse for Federal Scientific and Technical Information, Springfield, Virginia 22151. Requests for individual copies or questions relating to the Tech Brief program may be directed to the Technology Utilization Division, NASA, Code UT, Washington, D.C. 20546.

Spinarc Gas Tungsten Arc Torch Holder

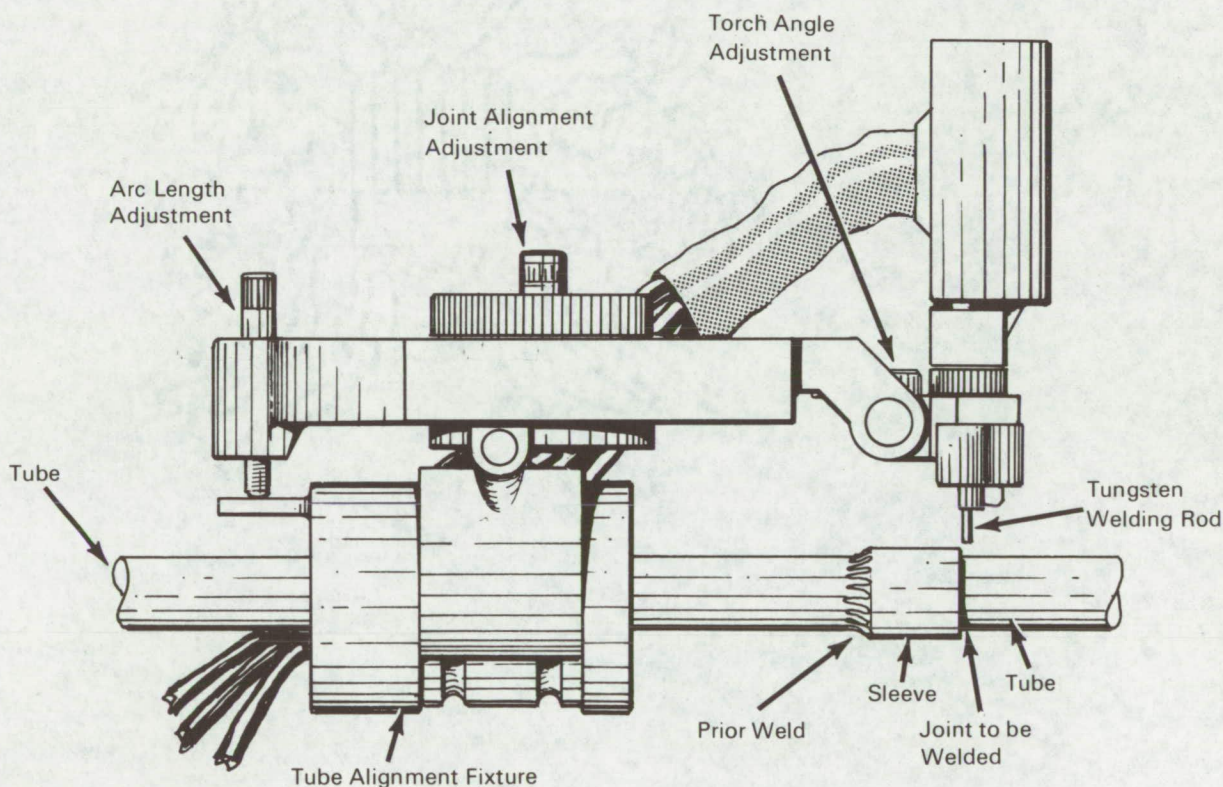

Torch, Torch Holder, and Tube Joint

A prototype device for semiautomatic gas tungsten arc (GTA) welding of small diameter aluminum tubing consists of a rotating fixture that may be attached to the tube requiring welding (see fig.). The welding torch is positioned in the holder, which is rotated around the weld joint. Because the torch nozzle is always centered over the weld joint where the arc is started, the arc length remains constant. Since the tungsten is preset

for the weld, arc initiation is easier and the process of "searching for the joint" through a dark welding lens is eliminated.

The device was fashioned into an air-cooled unit by modifying a commercial torch. This was accomplished by removing the water and gas lines and adding an adapter to permit gas to flow through the power cable hose. For clearance, the torch handle was also

(continued overleaf)

removed. Precise location of the tool on the tube was maintained by three rollers under spring tension. The torch operator was also able to control the arc length, torch angle, and spring tension by means of three points of adjustment on the tool.

Note:

This Tech Brief is complete in itself. No additional information is available.

Patent status:

No patent action is contemplated by NASA.

Source: J.L. Crockett and D.F. Brace of
North American Rockwell Corporation
Space Division
under contract to
Manned Spacecraft Center
(MSC-15646)