

August 1970

KSC HQS.

-1-

Brief 70-10008

# NASA TECH BRIEF



NASA Tech Briefs announce new technology derived from the U.S. space program. They are issued to encourage commercial application. Tech Briefs are available on a subscription basis from the Clearinghouse for Federal Scientific and Technical Information, Springfield, Virginia 22151. Requests for individual copies or questions relating to the Tech Brief program may be directed to the Technology Utilization Division, NASA, Code UT, Washington, D.C. 20546.

## Telemetry Receiver

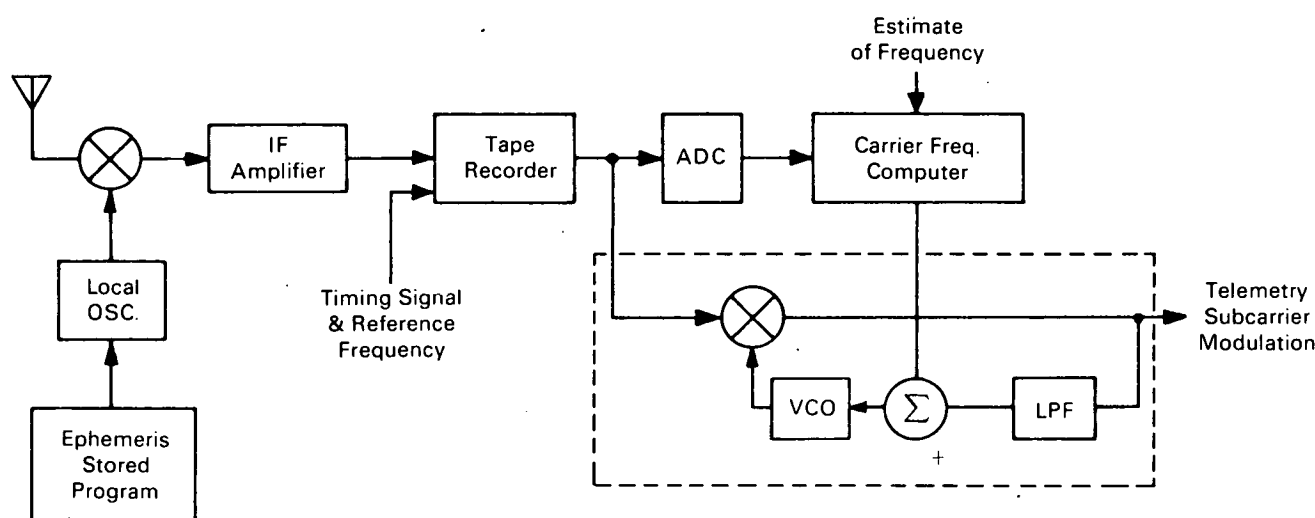

Block Diagram of Telemetry System

A communications system has been developed with an important feature of maintaining phase lock of weak telemetry signals with a minimal expenditure of power and bandwidth. Direct potential application would be in the commercial satellite communications network. The electronics hardware can also be used as an aide to commercial navigation (ship-to-shore) and in long range, fixed-point earthbound telemetry networks.

### The problem:

Telemetry signals received from a capsule entering a planetary atmosphere are weak and subjected to large Doppler dynamics. The received signal frequency is a function of time that is only predictable to a zero or first order approximation. It would be possible, by means of a wide band coherent receiving system, to maintain phase lock with the telemetry carrier under conditions of planetary entry. However,

the power requirements of the capsule transmitter would be prohibitively high for the wide bandwidth required.

### The solution:

An estimate of the frequency variation as a function of time can be made by preprocessing a recorded version of the received signal in nonreal time, and using that estimate to perform an aided tracking operation whereby coherent phase demodulation can be achieved with a minimal use of the available bandwidth. This allows most of the transmitted energy to be put in the information-carrying sidebands rather than in the carrier.

### How it's done:

A block diagram of the receiving system is shown in the figure. The received signal from the space probe is mixed in the detector with a local oscillator signal which is programmed according to an ephemeris pro-

(continued overleaf)

gram from the storage. This program subtracts out the components of Earth's rotation, the assumed trajectory of the capsule, and the Earth/planet relative motion. The output of the detector is a signal at an intermediate frequency with some of the known Doppler dynamics such as Earth's rotation, Earth/planet relative motion and assumed trajectory subtracted out. This signal is amplified and filtered in an i.f. amplifier and recorded on a magnetic tape recorder. The output of the recorder is converted to digital signals by an analog-to-digital converter and applied to a spectrum estimator computer. This computer can be a specialized digital device to perform the specific task or, alternatively, can be a general purpose computer utilizing a spectrum estimation program. The remaining function of the receiver, i.e., the phase-lock demodulation, can also be accomplished in software if desired, by employing a phase-lock-loop simulator program.

The computer estimates the frequency in each of the segments of the Doppler frequency vs time curve and algebraically adds the carrier frequency estimate from the tape recorded telemetry signal. The algebraic sum is then recycled and compared with the recorded telemetry signal. This process is repeated until the error in the estimate is reduced to the degree of smoothness where the residual frequency can be tracked by the phase-lock-loop. The telemetry modu-

lation output is then available at the output of the phase-lock-loop. By this iterative estimation of the carrier frequency vs time, the signal dynamics can be reduced so that the remaining signal is perturbed only by the additive noise and the error in the estimate. The remaining signal is narrow band and can be tracked by a narrowband phase-lock-loop.

**Note:**

Requests for further information may be directed to:  
Technology Utilization Officer  
NASA Pasadena Office  
4800 Oak Grove Drive  
Pasadena, California 91103  
Reference: B70-10008

**Patent status:**

This invention is owned by NASA, and a patent application has been filed. Royalty-free, nonexclusive licenses for its commercial use will be granted by NASA. Inquiries concerning license rights should be made to NASA, Code GP, Washington, D.C. 20546.

Source: R. Mathison, C. Gilchrist,  
and R. Goldstein of  
Caltech/JPL  
under contract to  
NASA Pasadena Office  
(NPO-10746)