

Feb. 18, 1969

3,428,923

JAMES E. WEBB
ADMINISTRATOR OF THE NATIONAL AERONAUTICS
AND SPACE ADMINISTRATION

BROADBAND CHOKE FOR ANTENNA STRUCTURE

Filed Feb. 15, 1967

Sheet 1 of 2

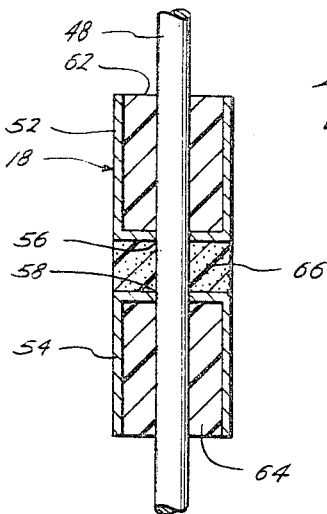
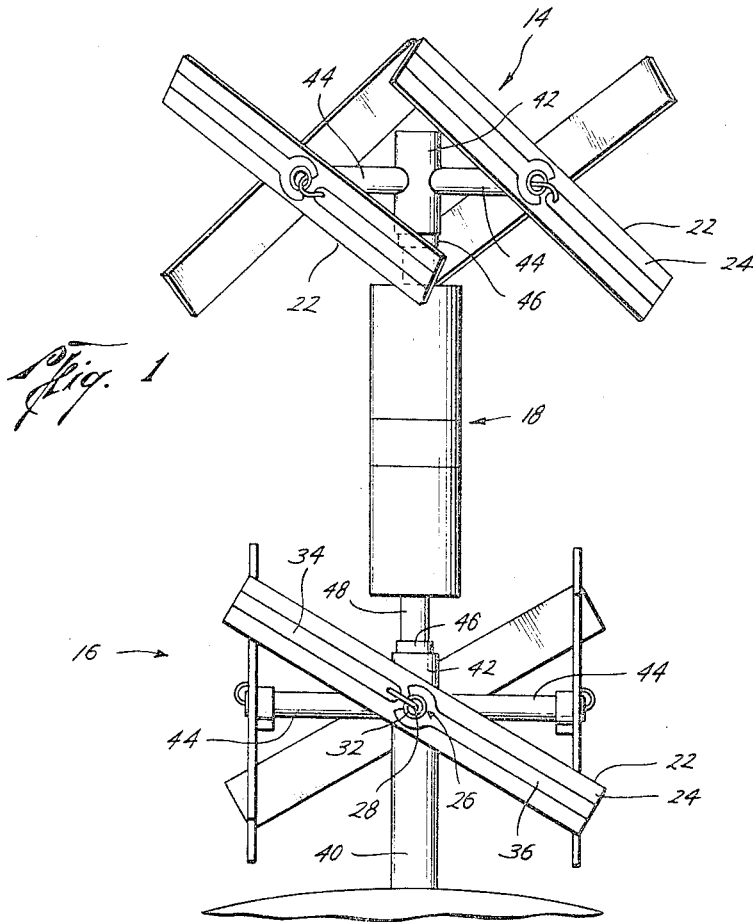

Otis L. Bishop
Conway A. Bolt, Jr.
INVENTORS

BY
Otis L. Bishop
Conway A. Bolt, Jr.
ATTORNEYS

Feb. 18, 1969

JAMES E. WEBB
ADMINISTRATOR OF THE NATIONAL AERONAUTICS
AND SPACE ADMINISTRATION

3,428,923

BROADBAND CHOKE FOR ANTENNA STRUCTURE

Filed Feb. 15, 1967

Sheet 2 of 2

Fig. 3

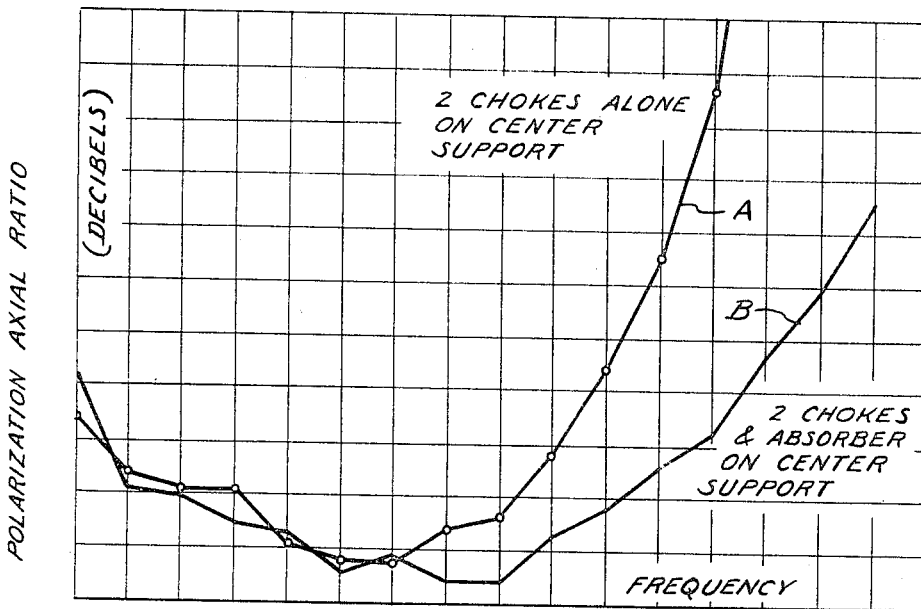
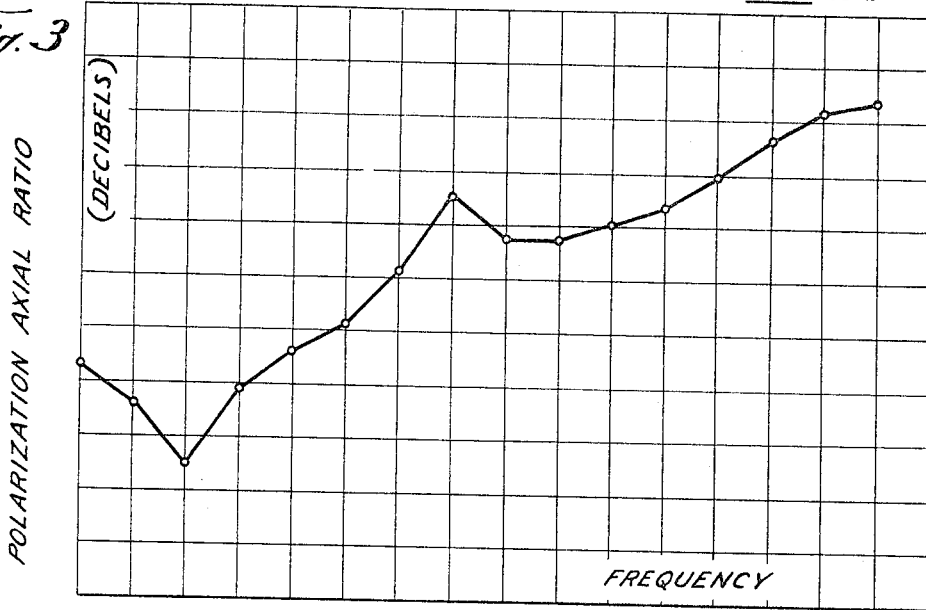

Fig. 4

Otis L. Bishop
Conway A. Bolt, Jr.
INVENTORS

BY *Gins & Co*
Harold Hertz
ATTORNEYS

3,428,923
**BROADBAND CHOKE FOR ANTENNA
 STRUCTURE**

James E. Webb, Administrator of the National Aero-
 nautics and Space Administration with respect to an invention
 of Otis L. Bishop, Glen Burnie, and Conway A. Bolt, Jr.,
 Pasadena, Md.

Filed Feb. 15, 1967, Ser. No. 617,022

U.S. Cl. 333-97
 Int. Cl. H01p 1/00

4 Claims

ABSTRACT OF THE DISCLOSURE

A support structure containing a coaxial line feed system is used to connect a pair of arrays for radiating circularly polarized waves which produces a doughnut shaped field pattern. Mounted on the support structure are a pair of quarter wavelength shaped chokes whose shorted ends are connected by an absorbing type material. At the center frequency of interest, the quarter wavelength chokes present open circuits to the currents induced on the support structure. At frequencies off center, those currents which are not suppressed by the choke are absorbed by the absorbing material. Thus, the resulting field pattern is not affected by currents induced in the support structure.

The invention described herein was made in the performance of work under a NASA contract and is subject to the provision of Section 305 of the National Aeronautics and Space Act of 1958, Public Law 85-568 (72 Stat. 435; USC 2457).

The invention relates in general to spurious current suppression, and more particularly to a broadband choke arrangement for use in an antenna structure.

Structural members for supporting a radiating element or joining radiator elements of an antenna array can by virtue of their position in the radiation field support currents induced on them by the radiating elements. While elimination of all structural support members is desirable, it is usually impossible. Further, the support structure is often used as the feed system to connect the transmitter or receiver to the radiating elements. Moreover, when the support structure is used to support an array for radiating a circularly polarized wave, due to currents induced in the support structure, the resultant waveform would be elliptically polarized. Thus, the resultant radiation pattern may be undesirable.

The use of quarter-wavelength shorted chokes on a structure to present discretely located open circuits to currents and thereby eliminate or reduce the magnitude of the currents, thus reducing the effects of the unwanted currents on the total radiation pattern is well known. In support structures used to join multiple radiating elements, the use of multiple chokes may be needed. Because of the possibility of physical blockage of the radiation pattern, chokes used for this purpose must be restricted in size. This size restriction, if applied to the choke diameter, will limit the usable frequency bandwidth of the choke arrangement. Further, while multiple chokes on a support operate well to suppress currents over a narrow frequency band, at frequencies removed from the resonant frequency, the chokes may be detrimental to the polarization ellipticity of the radiation from the antenna.

In order to overcome the undesirable effects upon the radiation pattern of an antenna array caused by the support structure, the present invention suppresses currents over a broad frequency range so that the resultant radiation pattern is not affected by the currents induced in the support structure. Thus, support elements are not minimized and a stronger physical structure is possible.

More particularly, according to a preferred embodiment of the invention, a support structure containing a coaxial line feed system is used to connect a pair of arrays for radiating circularly polarized waves which produces a doughnut shaped field pattern. Mounted on the support structure are a pair of quarter wavelength shaped chokes whose shorted ends are connected by an absorbing type material. At the center frequency of interest, the quarter wavelength chokes present open circuits to the currents induced on the support structure. At frequencies off center, those currents which are not suppressed by the choke are absorbed by the absorbing material. Thus, the resulting field pattern is not affected by currents induced in the support structure.

The advantages of this invention, both as to its construction and mode of operation, will be readily appreciated as the same become better understood by reference to the following detailed description when considered in connection with the accompanying drawings in which like reference numerals designate like parts through the figures, and wherein:

FIG. 1 depicts an antenna array having the novel current suppressing system on the support structure thereof;

FIG. 2 depicts the support structure of FIG. 1 in greater detail;

FIG. 3 is a curve depicting the antenna pattern polarization ratio characteristics without the current suppression of FIG. 2, and

FIG. 4 are curves depicting typical antenna pattern polarization axial ratio characteristics with the current suppression system of FIG. 2.

A typical structure containing the choke in accordance with the invention, as shown in FIG. 1, comprises a pair of arrays 14, 16 which are interconnected by the choke structure 18 of the invention. Each of the arrays 14, 16 contain a plurality of radiating elements comprising printed circuit dipoles 22. The dipoles are mounted on a dielectric member 24 and a coaxial conductor 26 formed of an inner conductor 28 and an outer conductor 32 whose extension 34, 36, respectively, form the dipole radiating elements. Electrical signals are fed to the dipole elements through a coaxial feed within an antenna support member 40. The coaxial feed within the support member 40 is coupled directly to the array 16 and through the center of broad band choke structure 18 to the second antenna array 14. Each of the arrays contain a power divider section 42 having four branch coaxial lines 44 which feed the radiating elements. The sections 42 are interconnected by an inter-array coaxial transmission line 48 which forms a support and inner structure for the antenna. The broad band choke 18 is mounted on the outer surface of the member 48.

Referring now to FIG. 2, the broad band choke is shown in greater detail. Surrounding the outer surface of the structural member 48 are a pair of metal cup-shaped members 52, 54 whose open end portions face the arrays 14, 16, respectively. A hole is cut in the closed end portions of members 52, 54 to allow the structural member 48 to pass therethrough. The members 52, 54 are brazed or soldered at the hole openings 56, 58, respectively, so as to form a good electrical contact with member 48. The inner portion of the cup-shaped member is filled with the dielectric 62, 64, respectively. The length of the cup-shaped members is electrically a quarter wavelength when the dielectric is in the members. The end walls of each of the cup-shaped members are interconnected by an absorbing wafer 66 having a hole which allows the structural member 48 to pass therethrough, and has the same diameter as the cup-shaped members. Each of the chokes 52, 54 present open circuits to currents radiating on the outer surface of the structural member 48 when the antenna array

is operated at a frequency when the chokes are electrically a quarter wavelength apart.

Referring now to FIG. 3, with the array of FIG. 1 operated without chokes, as can be readily seen the polarization axial ratio varies such that without the chokes a circularly polarized wave is almost impossible to obtain, and the radiating pattern is elliptically polarized. As shown in FIG. 4, curve A, with the use of the two chokes on the support member, the polarization axial ratio is sufficiently reduced such that a circularly polarized wave is now possible at the resonant frequency.

With the absorbing wafer 66 inserted in the choke structure, the currents which are present on the support member are absorbed by the wafer 66 if they are not suppressed by the choke structure. These currents are usually more prevalent at frequencies off the center frequency of the quarter wavelength choke, and thus allow lower polarization axial ratios over a wide frequency band as can readily be seen in curve B, FIG. 4.

Thus, as can be readily seen, the chokes together with the absorbing wafer allows broadbanding for an effective current interruption over a wider frequency beam. The arrangement utilizes the two chokes to present open circuits on the support structure near the radiating elements and an absorber wafer between the two chokes. Each choke exhibits an open circuit at the resonant frequency and some other impedance at all other frequencies. At frequencies off resonance currents flow past the choke joint such that without the absorber wafer the choke outer bodies could support and radiate the out of phase currents. Further, the currents from each end would interact with opposite chokes and reduce the operating effectiveness of each choke. The absorber wafer attenuates the currents on the choke bodies and serves to isolate the two chokes as well as reduce the effective length of any potential radiating parasitic element to less than the length necessary to support currents. The absorber selected is an iron loaded silicone rubber base that gives high attenuation for size. A broad band choke arrangement approximately doubled the usable frequency range for the particular antenna shown in FIG. 1.

It should also be understood that the foregoing disclosure relates only to a preferred embodiment of the invention and that it is intended to cover all changes and modifications of the examples in the invention herein chosen for the purposes of the disclosure and which do not constitute departure from the spirit and scope of the invention.

What is claimed and desired to be secured by Letters Patent is:

1. A broadband choke arrangement for suppressing currents on a support structure comprising:

- a first cup-shaped choke concentrically mounted on said support structure having a side wall and an end wall connected thereto, said end wall being connected directly to said support structure;
- a dielectric member mounted within said choke, said choke together with said dielectric member having an electrical length of one-quarter wavelength at the center frequency of interest; and

means for attenuating currents induced on said support structure and said choke comprising an absorber wafer concentrically mounted on said support structure and having a first end portion and a second end portion, said end portions being perpendicular to said support structure axis and parallel to said end wall of said choke, said first end portion being mounted adjacent to said end wall of said choke.

2. A choke arrangement in accordance with claim 1 and further comprising a second cup-shaped choke concentrically mounted on said support having an end wall and a side wall, said second choke being similar to said first choke and having a side wall and an end wall, said second choke end wall being mounted adjacent to said wafer second end portion.

3. A choke arrangement in accordance with claim 2 wherein said absorbing wafer and said chokes are cylindrically shaped and have the same outer diameters.

4. A choke arrangement in accordance with claim 2 wherein said absorbing wafer is composed of an iron loaded silicon base.

References Cited

UNITED STATES PATENTS

2,986,735	5/1961	Scheldorf	-----	343—802
3,153,239	10/1964	Adams	-----	343—791

HERMAN KARL SAALBACH, *Primary Examiner.*

L. ALLAHUT, *Assistant Examiner.*

U.S. Cl. X.R.

333—12, 73, 79; 343—885