

Feb. 18, 1969

JAMES E. WEBB
ADMINISTRATOR OF THE NATIONAL AERONAUTICS
AND SPACE ADMINISTRATION

3,428,847

WATER COOLED CONTACTOR FOR ANODE IN CARBON ARC MECHANISM
Filed Feb. 17, 1967

Fig. 1

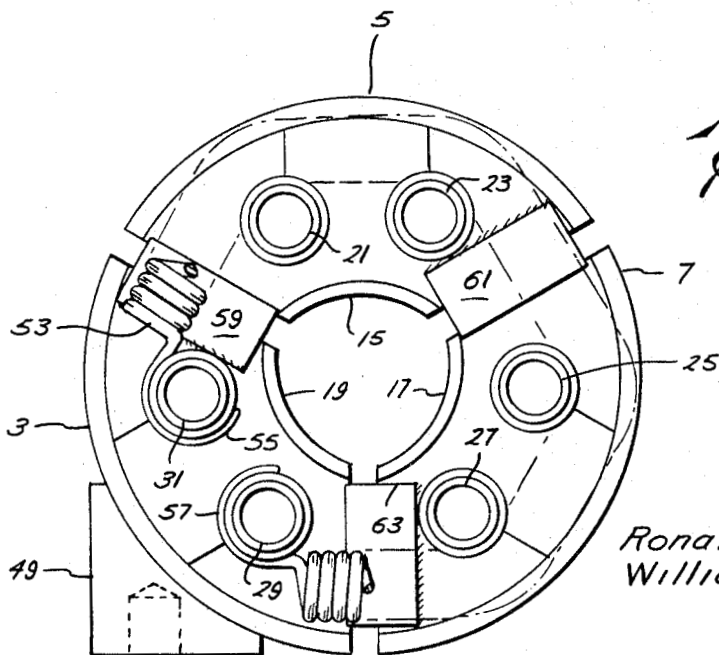
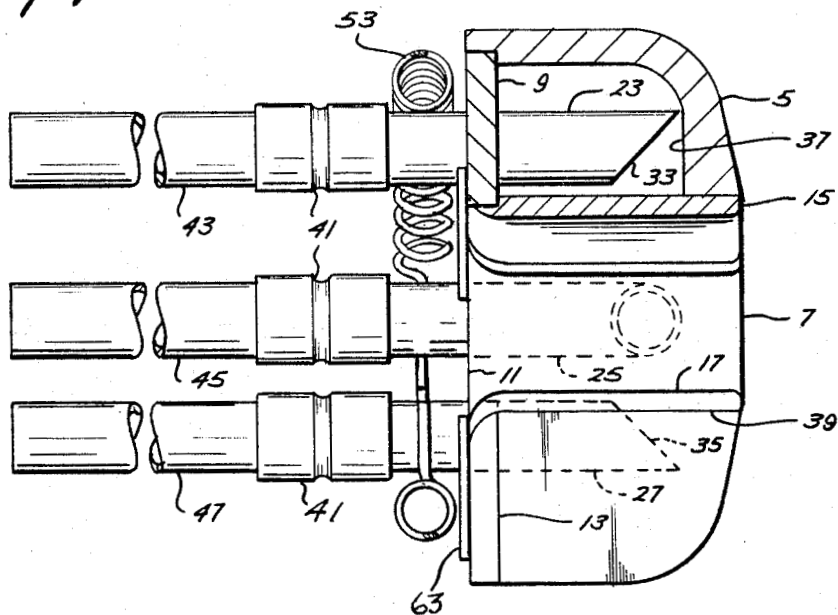

Fig. 2

Ronald E. Enstrom
William F. Schacht
INVENTORS

BY *Gene C. Coy*
BERNARD A. PELTER

ATTORNEY

1

2

3,428,847

**WATER COOLED CONTACTOR FOR ANODE
IN CARBON ARC MECHANISM**

James E. Webb, Administrator of the National Aeronautics and Space Administration, with respect to an invention of Ronald E. Enstrom, Skillman, and W. F. Schacht, Cherry Hill, N.J.

Filed Feb. 17, 1967, Ser. No. 617,783

U.S. Cl. 314-129

6 Claims

Int. Cl. H05b 31/18; B23k 9/28

ABSTRACT OF THE DISCLOSURE

The operational life of contacting devices for carbon arc rod holders suitable for use in high intensity, arc type illumination systems may be extended by utilizing a resiliently biased, radially expandible, three jaw configuration having silver-tungsten contact inserts secured to hollow housings. Inlet and outlet fluid conduits are provided for each hollow housing for flushing liquid coolant there-through.

The invention described herein was made in the performance of work under a NASA contract and is subject to the provision of section 305 of the National Aeronautics and Space Act of 1958, Public Law 85-568 (72 Stat. 435; 42 U.S.C. 2457).

This invention comprises a three piece jaw construction for holding and simultaneously cooling a rotating carbon anode and is particularly characterized by silver tungsten alloy inserts on the anode contacting surface which appreciatively contribute to its improved operational life.

BACKGROUND OF THE INVENTION

Field of the invention

The present invention pertains to contacting devices for carbon arc rods such as may be used in high intensity, arc type illumination systems. It is essentially of the internal-water cooled variety, and has external heat resistant alloy inserts on the rod contacting areas.

Description of the prior art

In high intensity arc lamps the positive head serves to guide the positive carbon in such a manner that its position is correctly centered with respect to the overall illumination system. When these lamps are operated at high current densities it is necessary to connect the arc current as near as possible to the tip of the rod. Due to the intense heat generated during burning of the positive carbon rod, the contactor or jaw which holds the rod while it is consumed normally has a relatively short operational life, even though various cooling features are incorporated in it. These cooling features typically take the form of air or other fluid nozzles located adjacent the heat transfer areas of the jaw. The jaws are generally of only two piece construction because of the inherent complexity in providing an additional cooling inlet and outlet duct for every additional jaw element. Two piece jaws, however, are particularly susceptible to carbon dust buildup and are characterized by poor distribution of contact pressure on the carbon rod. Equal distribution of jaw pressure is essential because the rod would otherwise be misaligned with respect to the lamp's optical system. Unequal pressure distribution also inhibits linear translation and rotation of the rod as it moves through the jaws during consumption. Due to these desirable but antagonistic design characteristics, that is multi element jaws and jaw cooling provisions, a jaw having long operational life (over 200 hours) is unknown to the prior art. The present invention is therefore directed to an improved water cooled contactor

for the anode in a carbon arc mechanism. It is characterized by markedly improved life span (over 300 hours), and is designed in three segment construction so as to be self cleansing. Due to its cantilever-type jaw supporting construction having spring biasing means to exert jaw pressure, the carbon rod moves freely through the contactor. Due to the geometry of the jaws, excellent electrical contact is maintained during rod movement. In addition, the rod contacting surfaces of the jaw segments contain an improved insert of silver-tungsten material. The silver component of the insert has good electrical conductivity, while the tungsten exhibits desirable arcing, welding, abrasion, and sticking resistance. These features, along with numerous others such as the internal jaw cooling system, contribute to the many improvements and advantages of the present invention. The above features and many others will become more apparent upon examination of the following detailed description, claims, and drawings wherein like numerals denote like parts in the several views and wherein:

FIG. 1 shows in partial cross section a side view of the improved contactor assembly;

FIG. 2 shows a front view looking along the axis of the positive carbon aperture.

As shown in FIGS. 1 and 2, the essential parts of the improved anode contactor constitute the three jaw segments 3, 5, and 7. Each of the segments are hollow in form and are enclosed along the contactor axial face by the respective jaw body inserts 15, 17, and 19. Communicating with each of the jaw segments is a pair of duct members 21, 23, 25, 27, 29, and 31. The face of the inlet duct members interiorly of each jaw segment is sloped, as for example at 33 and 35 of FIG. 1, so that water expelled therefrom will impinge in the forward contact corner area 37, 39 of the jaw segments. For example, in jaw segment 5 of FIG. 2, the conduit 23 supplies water to the hollow jaw. The water comes into contact with contactor element 15 and is removed from the jaw segment by return line 21. A continuous flow of water occurs in each jaw segment in this manner, thereby removing heat from the contactor.

Frictionally engaging the end of each of the aforementioned duct means is a cylindrical hollow coupling member 41. The coupling members, at their ends opposite the end engaging each duct, frictionally engage a length of copper tubing 43, 45, and 47. The tubing is in turn affixed to a source of water supply and return reservoir. One of the jaw segments 3 is structurally affixed to a primary alignment block 49 which may serve as the mounting block for the six water tubes (four of which act as supports for the two cantilevered jaw sections). These two segments 5 and 7 are supported in a cantilevered manner from the block in proximate relationship to jaw segment 3 by the aforementioned conduits 21, 23, 25, and 27 which are in turn connected to the tubing members. This arrangement provides for a floating type action in the jaw segments 5 and 7 which freely accommodate any curvature in the positive rod as it is fed through the contactor assembly. At the same time, segment 3 is fixed to provide an alignment reference. In order to maintain optimal pressure on the rod, however, a garter-type spring 53 is disposed around and in contact with the conduit members 21, 23, 25, and 27 of jaw segments 5 and 7, and is fixedly connected to the conduit members 29 and 31 of fixed jaw segment 3 by hook-like ends 55 and 57. It is thus seen that although two of the three jaw segments are cantilever mounted in a manner providing a floating type movement, there exists by reason of the garter-type spring 53 connected to the fixed jaw segment 3 sufficient pressure on the arc rod to keep it in properly optically aligned position. The garter spring which rests on the conduits is out of the direct light path of the burner and is protected

by a plurality of light shield members 59, 61 and 63, each affixed at only one end to a jaw segment.

The jaw inserts 15, 17, and 19 which may be affixed to the jaw as by soldering, have heretofore commonly been made of silver. Other jaw elements may be of copper. The use of an alloy such as silver-tungsten for the inserts shows markedly improved performance, however, over a much longer period of time when compared with the silver commonly used. The 50% silver 50% tungsten insert is a powder metallurgy product that combines the good electrical conductivity of silver with the arcing, welding, abrasion and sticking resistance of tungsten. The sintered product has an electrical conductivity that is about 55% of that of pure copper. Low contact resistance between the carbon and the contactor is aided by movement of the carbon rod which helps to break down any surface oxide films that form on the tungsten. The high electrical conductivity and the high resistance to arc erosion, sticking, and abrasion of the silver-tungsten insert contribute to the substantially improved life (300 hours or more) of the present invention. The 50% silver 50% tungsten inserts are attached to each jaw segment by any appropriate means such as by silver solder.

It should be pointed out that the theoretical contact of a round rod in a slightly larger round hole, such as exists in a contactor clamp, is a straight line. Thus when wear occurs in a two piece jaw there results two points of line contact, and in such case proper alignment is more difficult and carbon dust tends to build up in the contactor area. With the three piece jaw an oval rod hole is provided. The wear pattern has thus proved to produce an area contact rather than a line contact and even in the worst case it provides three points of line contact which increases the guaranteed contact area by a factor of 3 over 2, thus making stray movement difficult. This not only enhances optimal centering of the arc rod, but also results in a contactor which is substantially self cleaning insofar as the carbon dust problem is concerned.

An arrangement according to the present invention offers numerous advantages with respect to the constructions known heretofore. Division of the positive holder into three jaws, two of which are movable, prevents chocking and wedging of the carbon within the contactor piece. Current supply and cooling of the carbon is effected directly adjacent the arcing end so that losses in heating by the current are minimized. Cooling of the jaw at the same time prevents burning of the parts of the contactor which in conjunction with the improved silver-tungsten inserts markedly improves operational life. Also, by arranging all ducts and support means within the shadow of the jaws, loss of light is greatly avoided, this being extremely advantageous when an arc lamp cooperates with a concave reflector to produce a defined light beam. The absence of clamps or additional fixations for holding and advancing the carbon is particularly advantageous if the lamp is designed for continuous operation.

While there has been described above a form of the invention believed to be a preferred form, variations thereof will suggest themselves to those skilled in the art. All such variations as fall within the true spirit of the invention are intended to be comprehended within the generic terminology of the appended claims.

What is claimed is:

1. A contacting device for holding the arc rod for an arc lamp comprising:

a plurality of contacting jaw elements of complementary form, each having means thereon for cooperatively engaging the rod, said means consisting of silver-tungsten alloy inserts, there being approximately equal amounts of each material in the inserts,

one of said contacting jaw elements being fixedly mounted on a supporting block member and the remaining elements being mounted on an end of a cantilever arm in such a manner as to permit radial displacement with respect to the axis of the rod as it passes therethrough.

2. The contacting device of claim 1 wherein each of said jaw elements comprises hollow, fluid tight chambers and inlet and outlet fluid conduit means for transmitting cooling fluid to and from said chambers.

3. The contacting device of claim 2 wherein said fixedly mounted jaw element has holding means extending therefrom for receiving jaw element compression means;

said jaw element compression means contacting said cantilevered jaw elements and affixed to said holding means of the fixedly mounted jaw element for radially biasing the cantilevered jaw elements toward the axis of the carbon rod firmly engaged within said jaws by the biasing force of said compression means.

4. The contacting device of claim 1 wherein said fixedly mounted jaw element has holding means thereon for receiving the ends of an elongate jaw element compression means, said compression means having contacting relation to the external surface of each said jaw elements so that an inwardly directed compressive force is exerted on each said jaw elements.

5. The contacting device on claim 2 wherein;

said inlet fluid conduit means comprise a tube-like member in which the end wall thereof communicating with said hollow chambers is angularly sloped with respect to its axis so as to dispense coolant over the entire area of said hollow chambers.

6. The contacting device of claim 5 in which said jaw elements are three in number, the fluid conduit means for two of said elements comprising respective cantilever arms and

resilient compression means affixed to said third element and encircling both of said cantilevered jaw elements so as to bias all said elements into engagement with each other to thereby affirmatively hold the rod.

References Cited

UNITED STATES PATENTS

2,693,498	11/1954	Penberthy	13—17
2,788,459	4/1957	Gretener	13—16 X
2,899,477	8/1959	Cartoux	13—16
3,225,169	12/1965	Kosco	200—166

BERNARD A. GILHEANY, *Primary Examiner.*

R. N. ENVALL, JR., *Assistant Examiner.*

U.S. Cl. X.R.

13—15; 219—120