

Jan. 7, 1969

J. D. BIRD ETAL

3,420,471

JET SHOES

Filed Feb. 24, 1967

Sheet 1 of 2

FIG. 1a

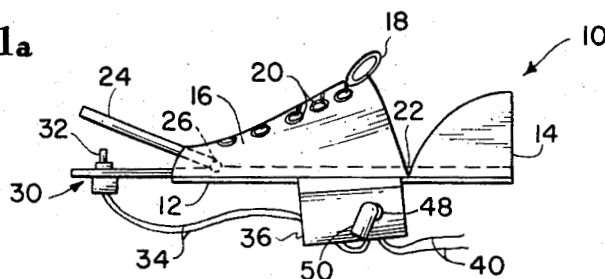

FIG. 1b

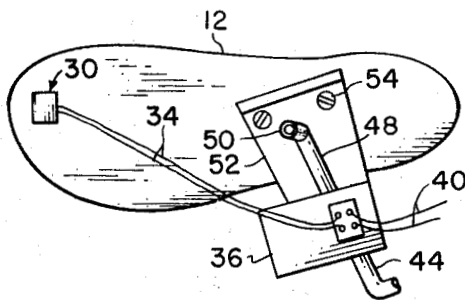

FIG. 2

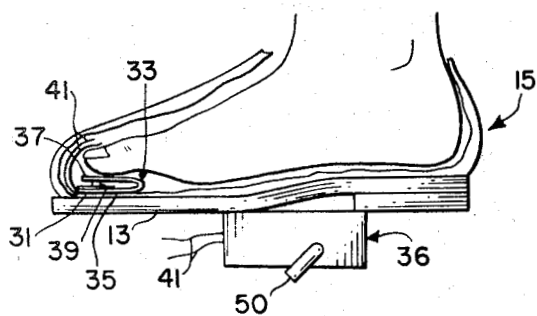
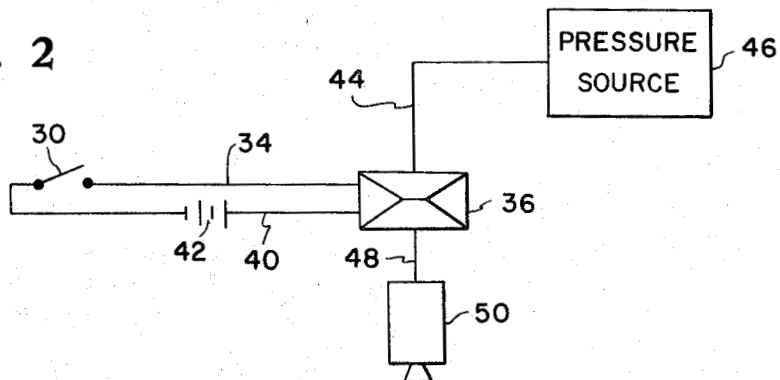

FIG. 3

BY

INVENTORS
 JOHN D. BIRD
 HOWELL D. GARNER
 ERNEST D. LOUNSBERRY
 DAVID F. THOMAS, JR.

Starn & Coy
Chardon McBride
 ATTORNEYS

Jan. 7, 1969

J. D. BIRD ETAL

3,420,471

JET SHOES

Filed Feb. 24, 1967

Sheet 2 of 2

FIG. 4a

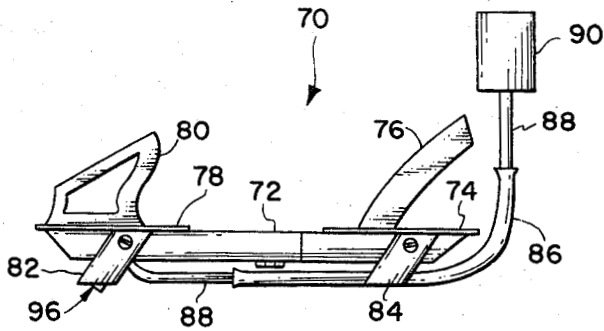

FIG. 4b

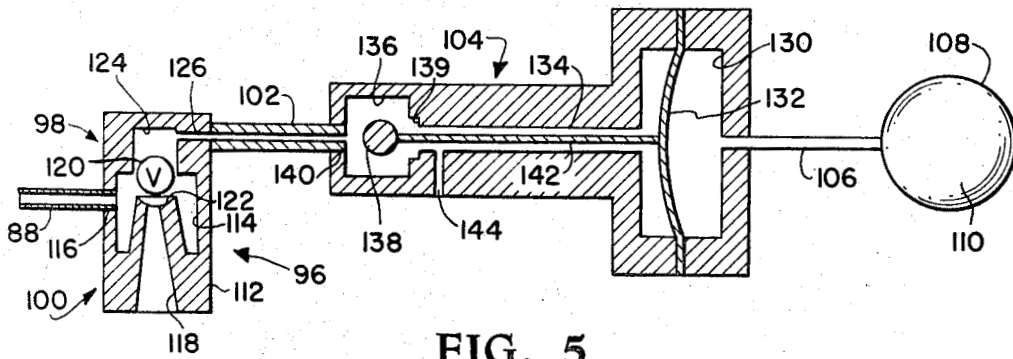
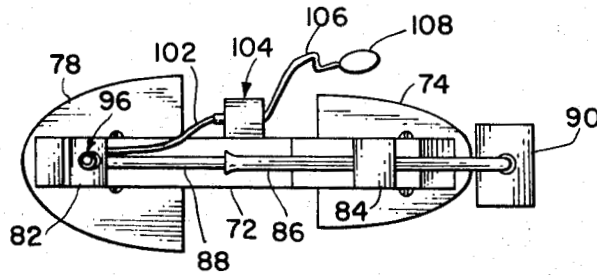

FIG. 5

INVENTORS
JOHN D. BIRD
HOWELL D. GARNER
ERNEST D. LOUNSBERRY
DAVID F. THOMAS, JR.

BY

Stans Coy
Clordon McBride
ATTORNEYS

1

2

3,420,471
JET SHOES

John D. Bird, Hampton, Howell D. Garner, Newport News, and Ernest D. Lounsberry and David F. Thomas, Jr., Hampton, Va., assignors to the United States of America as represented by the Administrator of the National Aeronautics and Space Administration
Filed Feb. 24, 1967, Ser. No. 619,520
U.S. Cl. 244—4
Int. Cl. B64c 39/00; F03h 5/00; A43b 5/00

11 Claims

ABSTRACT OF THE DISCLOSURE

An apparatus for attachment to the feet of a person desiring extravehicular space locomotion having a fluid thruster controlled by the toes of the person. Toe end heel attachment elements are utilized for securing a base that supports the thruster and a control circuit therefor to each foot. The control circuit is either electric, having a switch for energizing a solenoid valve permitting fluid to flow through a nozzle, or fluidic, having a syringe connected to a relay that operates a valve permitting fluid to flow through the nozzle.

Specification

The invention described herein was made by employees of the United States Government and may be manufactured and used by or for the Government for governmental purposes without payment of royalties thereon or therefor.

This invention relates generally to apparatus for extravehicular space locomotion and more particularly to apparatus for attachment to the feet of a person desiring such locomotion.

Previous devices designed for extravehicular space locomotion include hand-held space gun, Manned Maneuvering Units ranging from a strap-on pack to a "shirt sleeve" operated taxi, tractors and physically jumping from one point to another. All of the jet powered devices known heretofore have had the disadvantages of either requiring the use of one or both hands during use or utilizing a complex arrangement of control jets and gyroscopic sensors or requiring both the use of the hands and a complex control system. The jumping technique requires the application of a high degree of skill and judgment in using a surface at the proper angle and velocity. There is no assurance that future astronauts will have suitable platforms from which to jump to possibly a very small target. Furthermore, none of these systems utilize the instinctive capability of man to control his path and at the same time leave his hands free for other tasks.

In view of the above noted disadvantages it is an object of this invention to provide a simple, instinctively or naturally controlled device for locomotion under zero gravity conditions.

Another object of the instant invention is to provide a locomotion device for attachment to the shoes of a person to permit movement without requiring the use of one or both hands.

A further object of the instant invention is to provide a shoe or shoe attachment that supports a thruster controlled by the wearer's toes to effect locomotion.

Still another object of this invention is to provide a shoe attachment supporting a thruster activated by either an electrical or fluidic control circuit operated by manipulation of the toes of the wearer.

Yet another object of this invention is to provide a shoe attachment having a plate member capable of being

depressed by movement of the toes of the wearer that closes a switch to energize a solenoid valve and thereby permit pressurized fluid to flow through a nozzle and establish a force for locomotion of the wearer.

A still further object of the instant invention is to provide a shoe attachment wherein manipulation of a syringe controls a fluidic relay for operation of a valve permitting fluid flow through a nozzle to establish a force for locomotion of the wearer.

Generally, the foregoing and other objects are accomplished by attaching a thruster activated by either an electrical or fluidic control circuit operated by manipulation of the toes of the wearer. The electrical control circuit includes a depressible plate for closing a switch that energizes a solenoid valve to permit pressurized fluid to flow from a pressure source through the thruster nozzle. The fluidic control circuit has a syringe for compressing or expanding a fluid to operate a valve permitting pressurized fluid flow through the nozzle to effect a force for locomotion of the wearer.

A more complete appreciation of the invention and many of the attendant advantages thereof will be readily apparent as the same becomes better understood by reference to the following description when considered in connection with the accompanying drawings wherein:

FIG. 1 shows an embodiment of the instant invention in an elevation and bottom view;

FIG. 2 shows a diagrammatic sketch of the control circuit for the embodiment of FIG. 1;

FIG. 3 shows an alternative arrangement of a portion of the embodiment of the invention shown in FIGS. 1 and 2;

FIG. 4 shows an alternative embodiment of this invention in a side and bottom view similar to those of FIG. 1; and

FIG. 5 is a schematic diagram of the control circuit for the embodiment of the invention shown in FIG. 4.

Referring now to the drawings and more particularly to the embodiment of the invention shown in FIGS. 1 and 2 wherein jet shoes 10 are shown to include a base or longitudinal sole support 12 having heel attachment 14 and toe attachment 16. Toe attachment 16 is similar to a normal shoe in construction and utilizes laces 18 through eyes 20 for securement of base 12 to the shoe of the subject. Inner sole 22 may extend substantially the length of base 12 or some portion thereof. Toe plate 24 is pivotal about hinge 26 in order to permit depression thereof by the toes of the person on whom shoe 10 has been attached. Switch 30 is of conventional construction and is mounted on base 12 in a position to permit toe plate 24 to operatively engage button 32. That is, button 32 is maintained in a position such that switch 30 is open until button 32 is depressed against the spring or other internal mechanism for maintaining switch 30 open. Switch 30 is connected with solenoid valve 36 by electrical leads 34. Leads 40 connect solenoid valve 46 with power source 42 and switch 30 to provide a closed electrical circuit.

A source of high pressure fluid 46 is connected by line or conduit 44 to solenoid valve 36 and conduit 48 connects valve 36 with nozzle or thruster 50 to provide a system for permitting fluid flow from high pressure source 46 through valve 36 and out nozzle 50 to establish a thrust or force against base 12 and the person to whom the jet shoes have been attached. Solenoid valve 36 and nozzle 50 are attached to plate 52 that in turn is secured to base 12 as by screws or bolts 54.

It is readily apparent that in order to operate the instant invention in the vacuum environment of outer space, it is necessary to locate the switch in the boot of a space suit. FIGURE 3 shows switch 31 mounted on lower leg 35 of U-shaped member 33 made of a spring

metal. Upper leg 37 functions as plate 24, FIGURE 1a, in that its depression by the toes of the wearer causes button 39 of switch 31 to close the electrical circuit and energize solenoid valve 36. Member 33 is mounted on the inside of sole 13 of boot 15. Leads 41 connect switch 31 to solenoid valve 36 and are led from the inside of boot 15 in any conventional manner permitting maintenance of space suit integrity. Solenoid valve 36 and nozzle 50 are mounted on the outside of sole 13 of boot 15 in a conventional manner.

Referring now to FIGS. 4 and 5 wherein an alternative embodiment of the instant invention is shown to include "jet shoes" 70 having a base or beam 72 that would extend longitudinally along the bottom of the shoes of the person desiring extravehicular space locomotion. Heel plate 74 and heel attachment 76 are secured to base 72 as are toe plates 78 and toe attachment 80. Support or bracket 82 mounts thruster 96 on base 72 for a purpose to be described more fully hereinafter. Bracket 84 on base 72 supports protector 86 for protection of fluid line 88 which connects thruster 96 with fluid pressure source 90.

Thruster 96 includes valve 98 and nozzle 100 which, as seen in FIG. 5, are connected by vent line 102 to relay 104. Relay 104 is connected by a flexible tube or conduit 106 to thin metal syringe 108. Syringe 108 and flexible tube 106 are filled with a fluid 110 as will be described more fully hereinafter.

Thruster 96 includes valve 98 and nozzle 100. Casing 112 of thruster 96 has a larger inner chamber 114 connected to conduit 88 through aperture 116. Nozzle 100 includes divergent exhaust cavity 118 having interior seat 122 for ball 120 of valve 98. Smaller chamber 124 is of a dimension slightly larger than the diameter of ball 120 to permit ball 120 to be displaced by fluid pressure from line 88 in chamber 124. Aperture 126 connects vent chamber 124 with vent line 102.

Relay 104 includes a large basic chamber 130 divided by diaphragm 132 such that fluid 110 is permitted access only to a portion of chamber 130, flexible tube 106 and syringe 108. Bore 134 connects first chamber 130 with second chamber 136 which houses ball 138. Rabbet 139 provides a seat for ball 138 to close bore 134 and aperture 140 permits communication of vent line 102 and chamber 136. Rod 142 abuts diaphragm 132 and is moved thereby to control the position of ball 138 in second chamber 136. Vent 144 connects bore 134 with the surrounding atmosphere. It is to be understood that vent 144 could be located at any convenient position to connect either bore 134 or the nonfluid containing portion of chamber 130 with the surrounding atmosphere.

Operation

The embodiment of the instant invention shown in FIGS. 1 and 2 utilizes an electronic control circuit to activate the thruster. Depression of toe plate 24 by manipulation of the toes of the wearer closes switch 30 causing current to flow in leads 34. Because the circuit to power source 42 is closed, solenoid valve 36, which is of conventional construction, is energized and permits a pressurized fluid, such for example as nitrogen, to flow through lines 44 and 48 and, accordingly, through nozzle 50. As the gas issues from nozzle 50 a thrust is produced which acts more or less perpendicular to the sole of the shoe. The direction at which sole or base 12 is presented can be controlled by movement of the foot, ankle, knee or leg of the person to whom the shoes are attached. Release of pressure on toe plate 24 opens switch 30 de-energizing solenoid valve 36 which closes to prevent the flow of gas through lines 44 and 48 and nozzle 50 and thereby ceases the thrust. The alternative embodiment of the invention shown in FIG. 3 operates in a similar manner. Depression of leg 37 closes switch 31 to energize solenoid valve 36. The primary distinction between the embodiments shown in FIGS. 1 and 3 is the

insurance of space suit integrity which requires that switch 31 be located in boot 15 and connected to solenoid valve 36 by leads 41 led from the suit in a conventional manner.

Translational motions are primarily in the head foremost direction. Some lateral and fore and aft motions do occur as the result of inducing rotational motions. These motions are quite small in relation to the primary motion and are easily controllable. The wearer or subject's control of his motion is quite natural and instinctive in nature such that a short period of familiarization with the mechanics of the device is sufficient for the wearer to perform simple maneuvers. Control of the direction of translation is accomplished by rotating the body so that the head is pointed toward the target as in swimming. Rotations are controlled by the natural ankle and leg motions associated with balancing the body in a standing position. Thus, the native sense of balance of the wearer permits easy use of the instant invention because of the inherent stability and natural mode of locomotion.

The embodiment of the instant invention shown in FIGS. 4 and 5 functions in a manner similar to that of the device shown in FIGS. 1 and 3 but utilizes pneumatic or hydraulic principles for operation. Thin metal syringe 108 may be located inside the user's shoe under the toes or could be mounted in the sole of an astronaut's boots. Syringe 108 is emptied of control fluid, air or hydraulic fluid, by squeezing it with the toes. Control fluid 110 is forced through flexible tube 106 into chamber 130 of relay 104. As control fluid 110 enters relay 104 it causes movement of diaphragm 132 to effect longitudinal movement of rod 142. Movement of rod 142 to the left, FIG. 5, forces ball 138 from rabbet 139 and thus opens vent 144 and permits release of pressure from small chamber 124 in thruster 96. Fluid under pressure from source 90 enters chamber 114 through conduit 88 and forces ball 120 from seat 122 when small chamber 124 is vented through line 102 to chamber 136 and to the atmosphere through vent 144. However, with the vent line closed, the pressurized fluid from source 90 acts on the side and top surfaces of ball 120 and thereby forces ball 120 onto seat 122 and effects a seal to prevent further thrust.

Opening vent line 102 opens ball valve 98 that controls the flow of pressurized fluid, such for example as nitrogen gas, through nozzle cavity 118. Once open, the ball valve stays open as long as vent line 102 is open. Flow of the gas or fluid through nozzle 100 produces a thrust in the same manner as in the embodiment of FIG. 1. Expansion of syringe 108 withdraws control fluid 110 from relay 104 and the consequential closing of vent aperture 139 by ball 138. The pressure of the fluid entering chambers 114 and 124 from conduit 88 flows around ball 120 and forces it onto seat 122 to stop the thrust. The action of the above two-control systems, either the electrical or pneumatic-hydraulic type, is so rapid that the thrust can be pulsed as rapidly as the subject can move his toes.

A wide range of variation in design of the jet shoes is possible utilizing various power sources for the thrusters, control arrangements, and mountings of the thruster on the shoes or astronaut's boots. As for the thrusters, a jet utilizing a cold gas, such as nitrogen, would be about as simple as possible. Peroxide, a hot gas, jets could also be used. Throttleable jets would also be quite attractive for use with the instant invention. The principal requirement for the thruster is that the particular piece of equipment at which the thrust is produced be sufficiently compact that it may be mounted on the foot of the users. Skin divers, for example, might use small air driven propellers a few inches in diameter and rotating in a plane parallel to the soles of their feet in place of the jets.

The control system for the jets may take a number of forms basically either electrical, pneumatic, or hydraulic. The actual motion used to utilize the flow might be simply bending the toes as presently mechanized, bending the

toes both downward and upward, depending upon which direction of rotation is desired for rotational control, or using inertia as in kicking the feet in swimming. The second method would seem to be the most natural and the third would appear to be the most easily learned.

The thruster may be rigidly attached to the shoe in which event it would be positioned and aligned to suit the preference of the user. The device could incorporate an adjustable mounting in which case the individual would reposition the jets to suit himself. The most flexible arrangement would be a swivel mounting by which the user could augment the control deflection of the jet that is presently available from knee and ankle motions. The combination of a swivel mounted jet with a control linkage to augment control deflections, a hydraulic control system, using toe motions both up and down and the throttleable jets would provide a highly flexible, easily controlled system for extravehicular space operations.

This invention has the advantage over previous devices designed for extravehicular motion in that it is simple in design and reliable in operation. It can be made with but one moving part. That would be the main valve used to put the system on operational status which is not to be confused with turning the thrusters on. Since the control is instinctive, no electronic or inertia sensors are required for stabilization. Only two jets are required, one for each foot, as opposed to as many as sixteen on the more complex units. In addition, a very large advantage accrues to the jet shoe concept as the result of the control function being accomplished by the feet, which leaves the hands free for other tasks.

What is claimed as new and desired to be secured by Letters Patent is:

1. In a locomotion device the combination comprising: thrust means for creating a reaction force; mounting means for attaching said thruster means to the foot of a person; control means to modulate the thrust produced by said thrust means operable by movement of the foot of the person to which the thruster means is attached, whereby movement is obtained through forces applied to the foot and controlled by movements of the foot so that natural instinctive control may be had.
2. The locomotion device of claim 1 wherein said mounting means comprises: base means for securement to the foot of the person desiring locomotion; and support means for mounting said thruster means on said base; and wherein said thruster means includes a source of fluid pressure and means for directing flow of said fluid to create said reaction force.
3. The locomotion device of claim 2 wherein said control means comprises: an electric circuit including a resilient switch and power source; said switch mounted on said base means for operation by a plate upon movement of the toes of the person desiring locomotion; said thruster including solenoid valve means and nozzle means, whereby toe movement depresses said plate to operate said switch and thereby energize said solenoid valve to permit fluid to flow from said pressure source means through said thruster means creating a force for movement of the person desiring locomotion.
4. The locomotion device of claim 2 wherein said thruster includes nozzle means for directing fluid flow; and valve means for controlling the flow of fluid through said nozzle.
5. The locomotion device of claim 4 wherein said control means comprises: a syringe connected by a tube to relay means; said relay means connected to said thruster means,

whereby operation of said thrust means is accomplished by expansion or counteraction of said syringe.

6. The locomotion device of claim 1 wherein said nozzle means is directed downward and forward with respect to said support means, whereby greater angular positioning is accomplished by ankle and knee movements of the person desiring locomotion.

7. The locomotion device of claim 5 wherein said nozzle and valve means are housed in a casing:

said nozzle means comprising a large chamber connected with the small end of a divergent cavity; a conduit connecting said large chamber with said pressure source means; seat means at the small end of said cavity in said large chamber for receiving a ball to prevent fluid from flowing from said large chamber into said cavity; said valve means including a small chamber of less cross-sectional area than said large chamber; a vent tube connecting said small chamber with said relay means; and a ball of slightly less diameter than the cross-sectional dimension of said small chamber for closing the small end of said cavity.

8. The locomotion device of claim 5 wherein said relay means comprises:

a first chamber divided by a diaphragm into two portions; one portion of said chamber connected with said tube connected to said syringe; a second chamber connected with the other portion of said first chamber by a bore; an aperture connecting said second chamber with a vent tube leading to said valve means; a rabbit at the junction of said bore and said second chamber; a rod disposed in said bore having one end in juxtaposition to said diaphragm and the other end extending into said rabbit; a ball in said second chamber in juxtaposition to said other end of said rod and said aperture; and a vent connecting said bore and the other portion of said first chamber with the atmosphere, whereby compression of fluid in said one portion of said first chamber effects movement of said diaphragm to push said rod against said ball and thereby open said vent permitting communicating of said second chamber with the atmosphere.

9. The locomotion device of claim 8 wherein said nozzle and valve means are housed in a casing:

said nozzle means comprising a large chamber connected with the small end of a divergent cavity; a conduit connecting said large chamber with said pressure source means; seat means at the small end of said cavity of said large chamber for receiving a ball to prevent fluid from flowing from said large chamber into said cavity; said valve means including a small chamber of less cross-sectional area than said large chamber; a vent tube connecting said small chamber with said relay means; and a ball of slightly less diameter than the cross-sectional dimension of said small chamber for closing the small end of said cavity.

10. The device of claim 1 wherein forces created by said thruster means is directed downwardly from said person by said mounting means whereby the force applied by said thrust means is applied in a similar manner to gravitational forces.

11. The device of claim 10 wherein said control means is operable by the toes of the person to which the device is secured whereby instinctive flexing of said toes may be used to control said thruster means.

(References on following page)

3,420,471

7

References Cited

UNITED STATES PATENTS

1,784,761	12/1930	Smith	-----	280—11.11
2,585,045	2/1952	Schmidlin	-----	251—14 X
3,044,566	7/1961	Mayr	-----	180—3 ⁵ 280—11.11

8

MILTON BUCHLER, *Primary Examiner.*

T. W. BUCKMAN, *Assistant Examiner.*

U.S. Cl. X.R.