

December 1969

Brief 69-10716

# NASA TECH BRIEF



NASA Tech Briefs are issued to summarize specific innovations derived from the U.S. space program, to encourage their commercial application. Copies are available to the public at 15 cents each from the Clearinghouse for Federal Scientific and Technical Information, Springfield, Virginia 22151.

## Chromatographic Detection and Analysis of Traces of Hydrocarbons

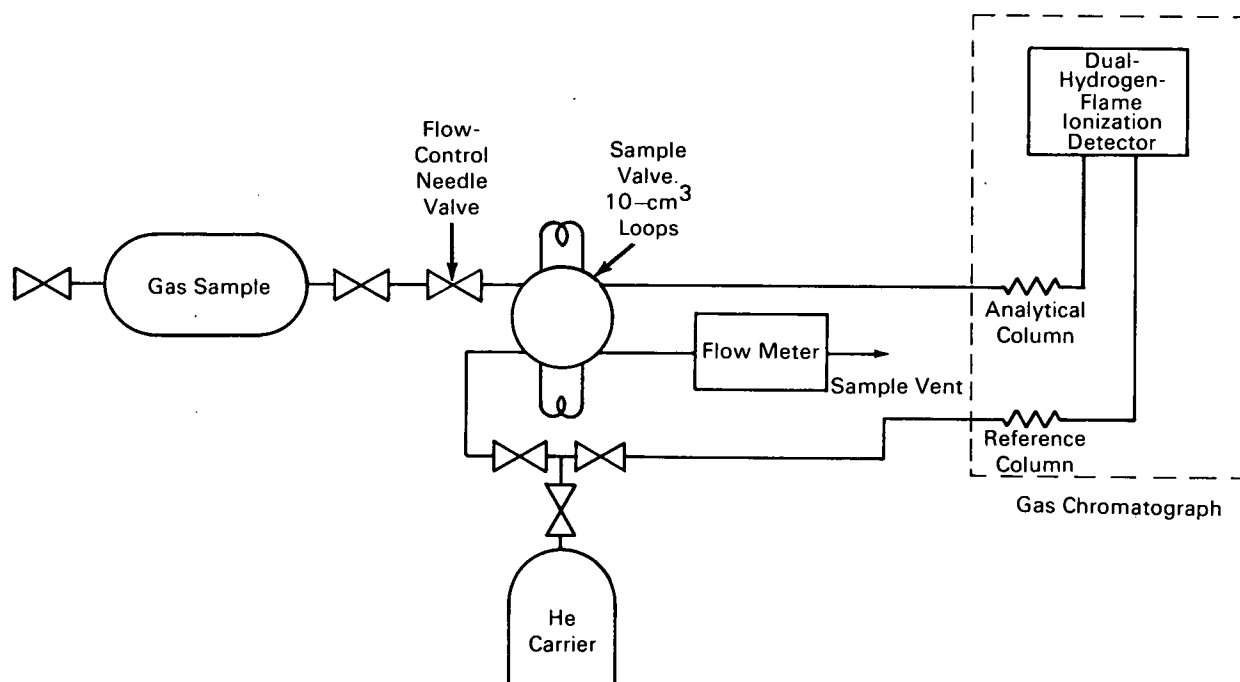

Figure 1. Schematic of the Apparatus

### The problem:

To develop a faster method for detecting and analyzing ethane, ethylene, acetylene, propane, and higher hydrocarbons in high-purity oxygen and air. The old method of detection required concentration of the hydrocarbons before analysis, a 3-liter sample of gas, and more than 50 minutes for execution.

### The solution:

A new technique uses a special analytical column having in series two separate absorption sections

charged with beads of porous polymer, and a 10-cm<sup>3</sup> sample of gas (Figure 1); the operation takes only 15 minutes.

### How it's done:

Each of the analytical and reference columns is a 4-foot stainless-steel tube, 0.25 inch in diameter, packed with 3 g of one type of activated beads plus 4 g of another type; both materials are 100/200-mesh absorbent beads of porous polymer. This series application of these materials enables a column to separate

(continued overleaf)

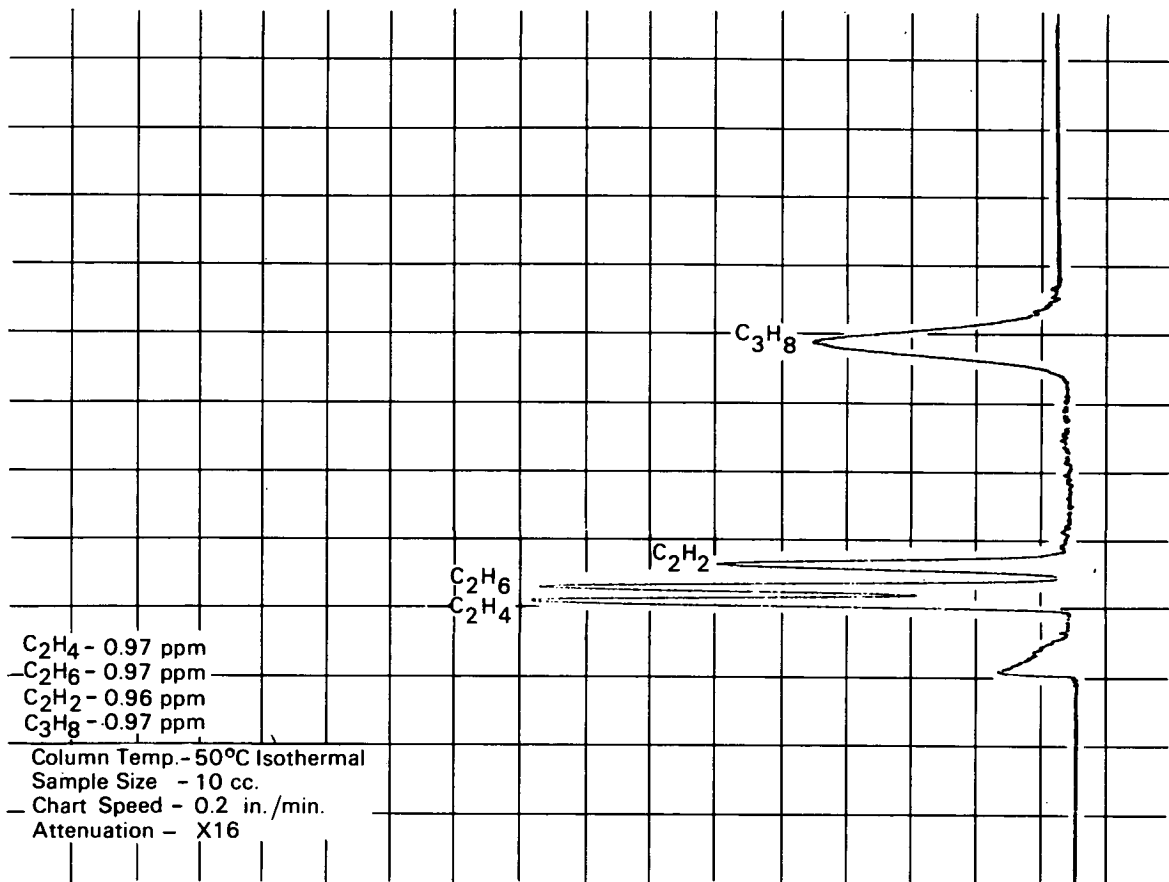

Figure 2. Elution Recording

specific hydrocarbons from oxygen or air. Use of these columns in conjunction with a gas chromatograph equipped with a dual hydrogen flame ionization detector makes possible direct analysis of oxygen or air containing specific hydrocarbons in the range of 20 parts per billion.

With the sample cylinder connected to the sample line of the instrument, the sample loop of the gas-sampling valve is purged through a flowmeter. The needle valve is closed, and the gas-sampling valve is quickly rotated for injection of a 10-cm<sup>3</sup> sample into the carrier-gas stream.

The elution of contaminants is then observed in the following order: ethylene, ethane, acetylene, propane, higher hydrocarbons (Figure 2). The degree of contamination, in parts per million, is the product of the factor, peak height, and attenuation. The factor is parts per million in the standard gas, divided by the product of peak height and attenuation.

The new technique may interest chemists; it is applicable in process control, production of high-purity gases, and investigation of air-pollution.

**Note:**

No additional documentation is available. Specific questions, however, may be directed to:

Technology Utilization Officer  
 Kennedy Space Center  
 Kennedy Space Center, Florida 32899  
 Reference: B69-10716

**Patent status:**

No patent action is contemplated by NASA.

Source: E. W. Fickey and H. E. Mullins of  
 The Bendix Corporation  
 under contract to  
 Kennedy Space Center  
 (KSC-10388)