

December 1969

Brief 69-10714

# NASA TECH BRIEF



NASA Tech Briefs are issued to summarize specific innovations derived from the U.S. space program, to encourage their commercial application. Copies are available to the public at 15 cents each from the Clearinghouse for Federal Scientific and Technical Information, Springfield, Virginia 22151.

## Flow Direction Measurement with Fixed Probes

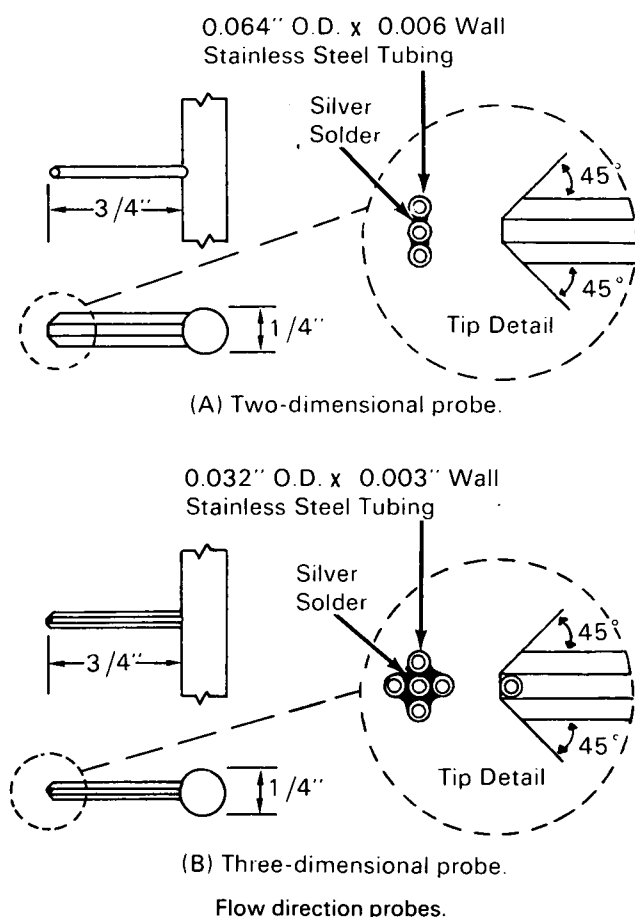

One of the quantities usually required in experimental fluid mechanics is fluid velocity. Therefore, in all but the simplest experiments, a measure of flow direction is required along with measurements of total and static pressure. Flow direction is usually determined from the indications of a pressure probe which

has symmetrically oriented taps that are sensitive to flow direction.

There are two methods in which the probe may be used. The first and most direct method is to rotate the probe until the direction-sensing pressures are nulled, which means that the probe is aligned with the flow.

In the second method, the probe is fixed and flow direction is determined from a correlation based on the relationship between probe pressures and flow direction.

Recently, there has been renewed interest in flow-direction measurement with fixed-position probes. The areas of interest include V/STOL fan studies, jet engine inlet distortion studies, and in-flight measurements on engine inlets.

There are several reasons for preferring fixed probes rather than rotatable ones. These reasons involve factors such as space limitations, system response, safety, complexity, and cost.

Information on flow-direction measurement with fixed probes has been limited in the ranges of Reynolds and Mach numbers. Therefore, fixed-position probes for the determination of flow direction in one and two planes were tested over a wide range of Reynolds number and Mach number. The work was limited to tests of a single probe design for two-dimensional flow and a single design for three-dimensional flow. The two designs are shown in the figure. The design for three-dimensional flow incorporates a central total pressure tube surrounded by four angled tubes. The design for two-dimensional flow has a central total pressure tube with two angled tubes.

Correlations were obtained for measured fixed-probe pressures against flow direction, total pressure,

(continued overleaf)

and static pressure. Flow direction is measurable to within one degree over combinations of flow conditions covering a range of Reynolds numbers from 1000 to 40,000, Mach numbers from 0.3 to 0.9, and flow angles from -30 degrees to +30 degrees.

**Note:**

1. Requests for further information may be directed to:

Technology Utilization Officer  
Lewis Research Center  
21000 Brookpark Road  
Cleveland, Ohio 44135  
Reference: B69-10714

**Patent status:**

No patent action is contemplated by NASA.  
Source: Lloyd N. Krause and Thomas J. Dudzinski  
Lewis Research Center  
(LEW-11044)