

November 1969

Brief 69-10649

NASA TECH BRIEF



NASA Tech Briefs are issued to summarize specific innovations derived from the U.S. space program, to encourage their commercial application. Copies are available to the public at 15 cents each from the Clearinghouse for Federal Scientific and Technical Information, Springfield, Virginia 22151.

High-Pressure Seals for Rotary Shafts

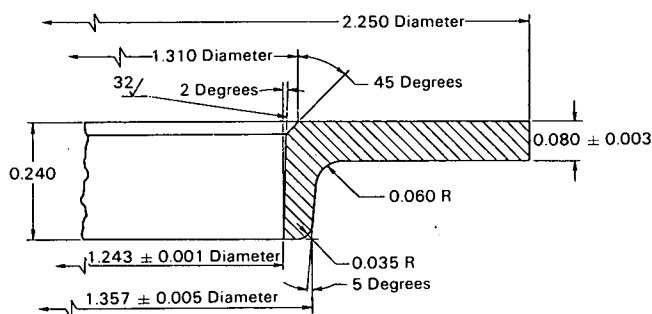

Fig. 1. Cross Section of a Seal (dimensions are in inches)

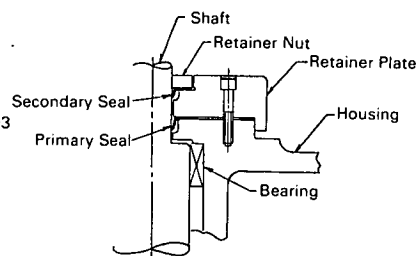

Fig. 2. Seal Assembly

The problem:

Development of 5,000-lb/in² seals for shafts rotating at temperatures between -400° and $+900^{\circ}$ F (500° F for continual operation).

The solution:

A new type of seal, machined from a polyimide resin, meets these specifications. It is more durable, longer-lived, and 85% cheaper than the older seal made of plastic-coated metal; it does not require the long stem now used on most cryogenic valves to form a gas pocket between the cold fluid and the seal.

How it's done:

The new seals are machined (fig. 1) from either blocks (available thicknesses, 0.25 to 2 in.), or sheets ranging from 0.015 to 0.060 in. in thickness. Available blocks are of the basic resin or contain one of three additions: 15% by weight of MoS₂, for unlubricated seals and bearings in vacuum or dry environments; 44% by weight of glass fibers, for precision parts in which only minimal thermal expansion is tolerable; or 15% by weight of graphite, for unlubricated seals and bearings.

A seal assembly comprises two lip-type seals: primary and secondary. The seals, separated by a retainer plate that is bolted to the housing, are locked in place by a retainer nut (fig. 2). A vent port in the retainer plate enables monitoring of leakage. The seal is suitable for all rotary machinery at speeds as high as 1,200 rev/min.

Notes:

1. The seal may interest designers or manufacturers of rotary machinery.
2. No further documentation is available. Inquiries may be directed to:

Technology Utilization Officer
Marshall Space Flight Center
Huntsville, Alabama 35812
Reference B69-10649

Patent status:

No patent action is contemplated by NASA.

Source: C. P. Holden of
North American Rockwell Corporation
under contract to
Marshall Space Flight Center
(MFS-18548)

Category 05