

# NASA TECH BRIEF

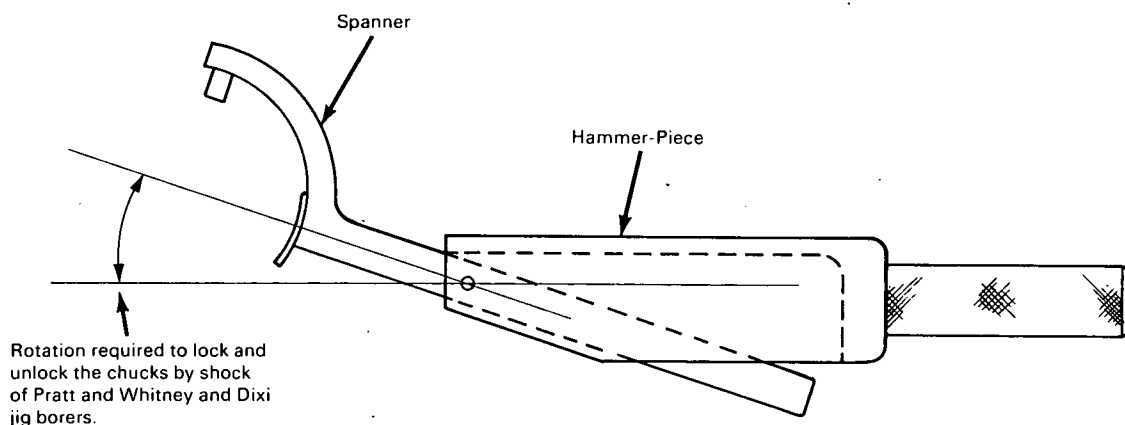

NASA Tech Briefs are issued to summarize specific innovations derived from the U.S. space program, to encourage their commercial application. Copies are available to the public at 15 cents each from the Clearinghouse for Federal Scientific and Technical Information, Springfield, Virginia 22151.

## One-Handed Hammer-Spanner for Chucks



### The problem:

To develop a modified spanner wrench that can be used with one hand for removal of a tool from a chuck. Two hands are generally needed to hold the standard wrench and strike it with a hammer.

### The problem:

A novel spanner having a heavy hammer-piece hinged to its handle. One hand is left free to grasp the released tool. A tool falling from the chuck may damage either itself or the workpiece.

### How it's done:

With the spanner, held in one hand, engaging the chuck, the same hand causes the hammer-piece to tap the handle of the spanner and so loosen the chuck. The other hand is thus free to grasp the released tool. The hammer-piece may be of any suitable metal such as steel or aluminum.

### Notes:

1. No similar wrench is available.
2. The standard spanner wrench has widespread use, and this modification should be of interest to the machining, fastener and bearing industries.
3. No further documentation is available. Inquiries may be directed to:

Technology Utilization Officer  
Marshall Space Flight Center  
Huntsville, Alabama 35812  
Reference: B69-10398

### Patent status:

Inquiries about obtaining rights for the commercial use of this invention may be made to NASA, Code GP, Washington, D. C. 20546.

Source: J. A. Martino and Steven Seid of  
North American Rockwell Corporation  
under contract to  
Marshall Space Flight Center  
(MFS-18581)  
Category 05