

September 1969

NASA TECH BRIEF



NASA Tech Briefs are issued to summarize specific innovations derived from the U.S. space program, to encourage their commercial application. Copies are available to the public at 15 cents each from the Clearinghouse for Federal Scientific and Technical Information, Springfield, Virginia 22151..

Shock-Absorbent Mountings for Bearings

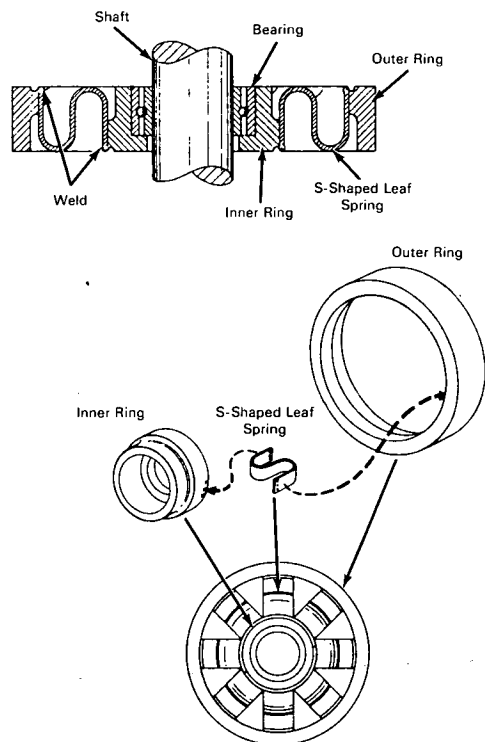

Fig. 1. Views of One Version of the Mounting

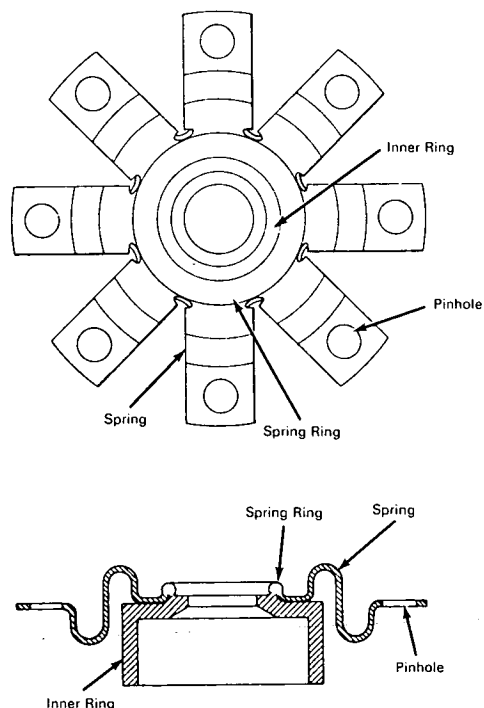

Fig. 2. Views of Another Version

The problem:

Design of a spring mounting to protect a bearing and its shaft from shock.

The solution:

A mounting for the bearing that consists of an inner and an outer concentric ring separated by a number of separate S-shaped rectangular leaf springs. Each end of each spring is secured to the inner or outer ring, and the bearing is carried in the inner

ring. Each spring can flex independently. The mounting can absorb shocks equivalent to 10,000g.

How it's done:

In one version (Fig. 1) the ends of the springs are welded to the inner and outer rings; annular grooves cut in the faces of the rings facilitate welding.

In another version (Fig. 2) the inner ends of the springs are integral with a spring ring; they are either made integral with the spring ring or welded to it.

(continued overleaf)

The spring ring is then fixed to and concentrically with the face of the inner ring by swaging or brazing. Near the outer end of each spring is a hole through which a pin (or a cap screw) fits for attachment to the host mechanism.

Other versions are possible. Such mountings have been used in rocket-borne tape recorders; they may interest manufacturers and users of bearings, especially for instruments.

Note:

No further documentation is available. Inquiries may be directed to:

Technology Utilization Office
NASA Pasadena Office
4800 Oak Grove Drive
Pasadena, California 91103
Reference: B69-10331

Patent status:

This invention is owned by NASA, and a patent application has been filed. Royalty-free, non-exclusive licenses for its commercial use will be granted by NASA. Inquiries concerning license rights should be made to NASA, Code GP, Washington D.C. 20546.

Source: Albert Topits, Jr., of
Jet Propulsion Laboratory
under contract to
NASA Pasadena Office
(NPO-10626)