

August 1969

Brief 69-10265

NASA TECH BRIEF



NASA Tech Briefs are issued to summarize specific innovations derived from the U.S. space program, to encourage their commercial application. Copies are available to the public at 15 cents each from the Clearinghouse for Federal Scientific and Technical Information, Springfield, Virginia 22151..

Technique for Anchoring Fasteners to Honeycomb Panels

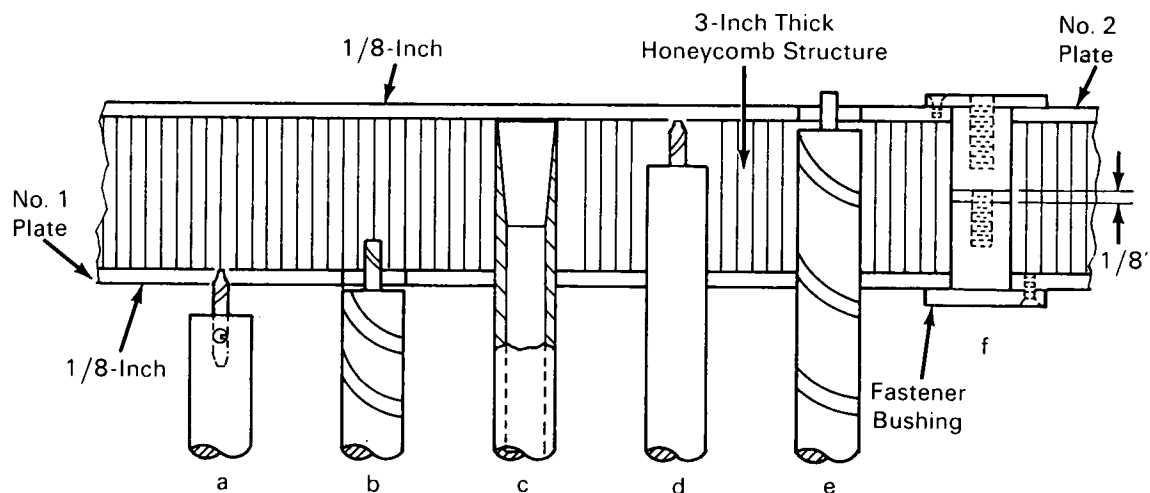

The problem:

To provide for the mounting of components on a 3-inch-thick honeycomb structure, it is necessary to drill $\frac{5}{8}$ -inch-diameter holes through the structure. The holes through the top and bottom plates of the honeycomb structure must avoid any misalignment. When the honeycomb core material between the plates is being drilled, any tearing of the adjacent honeycomb core must be avoided or the honeycomb structure will be weakened.

The solution:

A two-piece fastener bushing was threaded inside the hole, (f), to provide the mounting surface for the components. To avoid misalignment, a specially constructed starter drill and sheet metal drill are used. A tapered knife-edge cutting tool removes the honeycomb core material cleanly without tearing the adjacent material.

How it's done:

The fastener bushing used has a $\frac{5}{8}$ -inch body diameter, and therefore dictates the basic body size of each tool. The first operation is shown in (a). A $\frac{3}{16}$ -inch-diameter starter drill is inserted into a $\frac{5}{8}$ -inch-diameter rod and held in place by set screws. This tool provides a $\frac{3}{16}$ -inch pilot hole through plates No. 1 and No. 2 only for operations (b) and (e). A $\frac{3}{16}$ -inch-diameter drill pilot is machined at the tip of a $\frac{5}{8}$ -inch sheet metal drill, Figure (b). The drill pilot aids in holding alignment while drilling a $\frac{5}{8}$ -inch hole through plate No. 1. The honeycomb core drill is shown in (c), and consists of a tool-steel tube with a tapered-knife cutting edge; the knife cutting edge prevents any tearing of the honeycomb core which may occur with a regular drill. The honeycomb material is gathered in the center of the tube and removed with the tool. The starter drill is again used in (d) to provide the pilot

(continued overleaf)

hole (through plate No. 2) for the $\frac{5}{8}$ -inch sheet metal drill, operation (e). The solid $\frac{5}{8}$ -inch-diameter shaft of the starter drill will keep the pilot drill from walking on plate No. 2 and maintains good alignment with the $\frac{5}{8}$ -inch-diameter hole in plate No. 1.

The fastener bushing will bottom against the honeycomb structure with a space of approximately $\frac{1}{8}$ -inch between the two halves. The fastener is pulled up snug to the honeycomb structure by a pair of spanner wrenches. Each half of the fastener is then bolted to the top and bottom plates of the honeycomb structure in order to prevent its unscrewing.

Notes:

1. Operations (a) and (b) could be combined by either inserting into the tip of the sheet metal drill a $\frac{3}{16}$ -inch starter drill which would then be held in place by set screws, or by machining and forming a starter drill at the tip of the sheet metal drill.
2. No further documentation is available.
3. Technical questions may be directed to:
Technology Utilization Officer
Lewis Research Center
21000 Brookpark Road
Cleveland, Ohio 44135
Reference: B69-10265

Patent status:

No patent action is contemplated by NASA.

Source: A. C. Spagnuolo, W. J. Brown,
and J. C. Stonebraker
Lewis Research Center
(LEW-10888)