

August 1969

Brief 69-10261

# NASA TECH BRIEF



NASA Tech Briefs are issued to summarize specific innovations derived from the U.S. space program, to encourage their commercial application. Copies are available to the public at 15 cents each from the Clearinghouse for Federal Scientific and Technical Information, Springfield, Virginia 22151.

## Repair of Honeycomb Panels with Welded Breakaway Studs

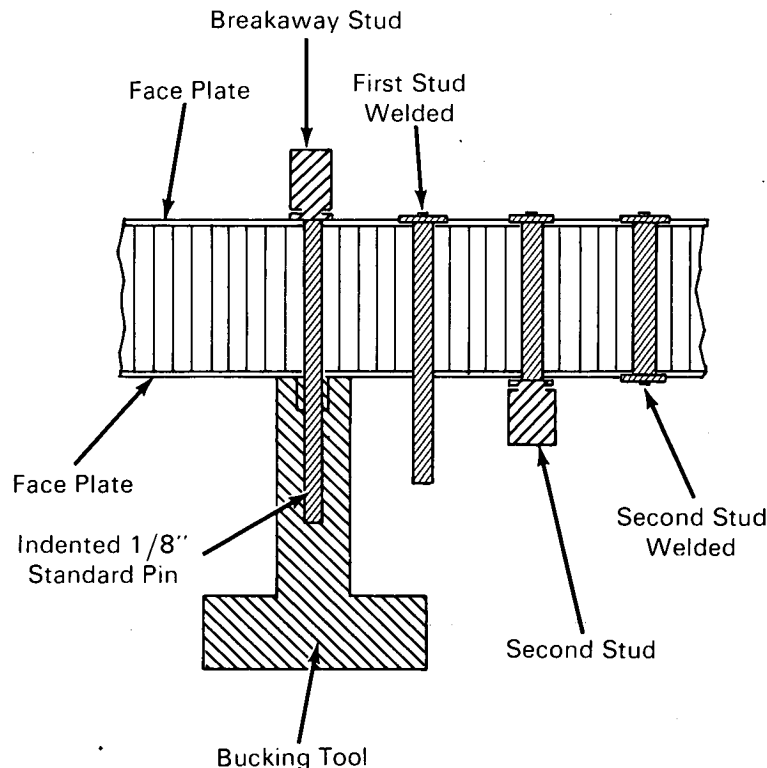

### The problem:

Prior methods of repairing damaged metallic honeycomb panels consisted of spot brazing or welding a doubler to the facing sheet. The excessive heat of brazing or welding weakened and often caused distortion or damage to panels and prevented repair in areas where only minimum heat is allowed.

### The solution:

By drilling holes and welding breakaway studs to both facing sheets, damaged panels can often be

repaired without the use of doublers and with greater strength when doublers are used. Since this method requires minimal heat in welding, it greatly reduces the distortion of highly stressed panels. This makes possible the repair of panels which otherwise could not be repaired.

### How it's done:

Using a number-30 drill, holes are drilled at a 90° angle through both facing sheets of a 1-inch-thick panel; the burrs are removed. A 1/8-inch-diameter

pin, held in a bucking tool, is placed through the holes and adjusted so that its exposed end is flush with the outer surface of the far sheet when the bucking tool is held hard against the opposite sheet; its end is indented. With a contact gun, the projection of a breakaway stud is driven into the dent in the end of the pin, and the stud is welded to both the face sheet and the pin while the bucking tool is held hard against the opposite sheet. The body of the stud is then twisted-off with pliers, using a circular motion, before the bucking tool is removed and the pin is torque-tested to 10 inch-pounds.

The other end of the pin, cut flush with the face sheet, is then indented with a Starrett No. 18-A automatic center punch; another breakaway stud is inserted in the dent. Again the stud is welded to pin

and face sheet before its body is twisted-off with pliers.

When this technique is used in conjunction with a doubler, the doubler is treated as though it were the face sheet.

**Note:**

This Tech Brief is complete in itself. No additional information is available.

**Patent status:**

No patent action is contemplated by NASA.

Source: D. F. Bruce of  
North American Rockwell Corporation  
under contract to  
Manned Spacecraft Center  
(MSC-15046)