

July 1969

NASA TECH BRIEF



NASA Tech Briefs are issued to summarize specific innovations derived from the U.S. space program, to encourage their commercial application. Copies are available to the public at 15 cents each from the Clearinghouse for Federal Scientific and Technical Information, Springfield, Virginia 22151.

J-Beveling of Pipe Ends with a Hand-Held Tool

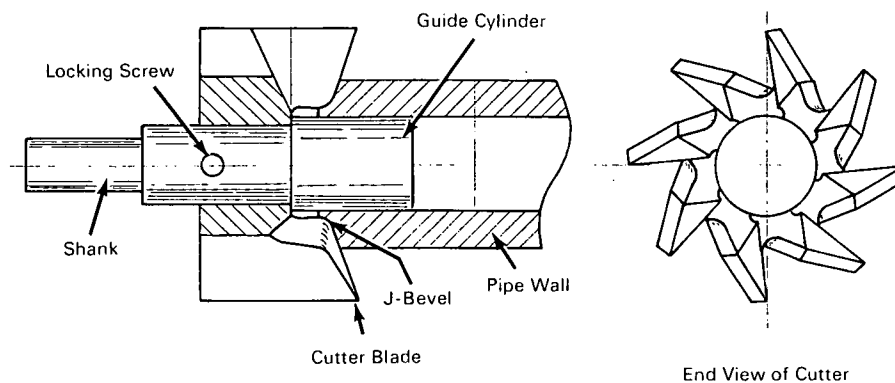

The problem:

To provide a tool that can be used in the field to cut J-bevels on the ends of stainless-steel or aluminum pipe to be joined by precision welding. When appropriate tools are not available in the field, bevels are roughed-out with an air grinder and then finished by manual filing. This method is very slow and results in many rejects.

The solution:

A J-bevel cutter adapted to be driven by a hand-held, variable-speed power drill. The cutter is mounted on a shaft having a 0.5-inch shank, which fits into the drill chuck, and a guide cylinder matching in diameter the bore of the pipe. To use the tool, the operator simply slides the guide into the pipe, turns on the power, and applies the cutter to the pipe end. Different sized cutters and guides are required for different pipe diameters. With this tool an acceptable bevel can be cut within 3 percent of the time required for grinding and filing.

Notes:

1. A single shop tool that prepares a pipe end for precision welding by simultaneously performing internal machining, end facing, and J-bevel cutting to precise standards is described in NASA Tech Brief 69-10231.
2. Other portable tools that prepare pipe ends for weld joining are described in NASA Tech Briefs 66-10145 and 68-10551.
3. No further documentation is available. Inquiries may be directed to:

Technology Utilization Officer
Kennedy Space Center
Kennedy Space Center, Florida 32899
Reference: B69-10229

Patent status:

No patent action is contemplated by NASA.

Source: S. T. Matus of
The Bendix Corporation
under contract to
Kennedy Space Center
(KSC-10356)

Category 05