

August 1969

Brief 69-10164

NASA TECH BRIEF



NASA Tech Briefs are issued to summarize specific innovations derived from the U.S. space program, to encourage their commercial application. Copies are available to the public at 15 cents each from the Clearinghouse for Federal Scientific and Technical Information, Springfield, Virginia 22151.

Detachable Caster Adapter

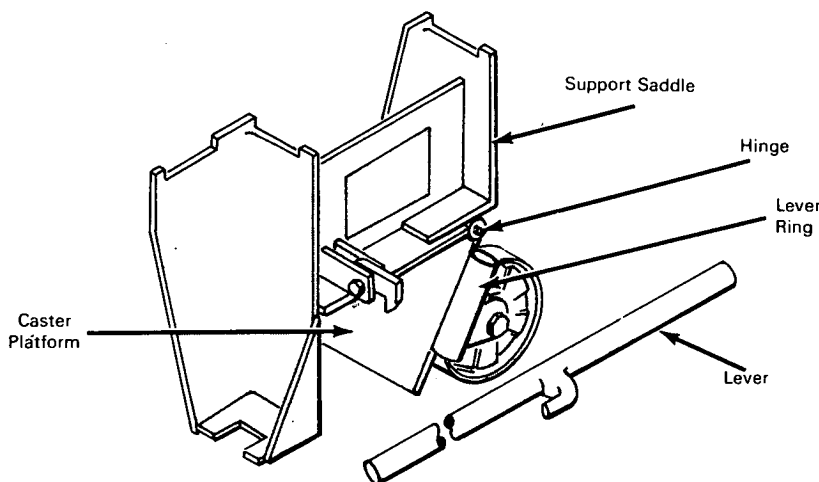

Quick Detach Caster Adapter
For Moving Weld Tables

The problem:

To provide a convenient means of moving heavy welding tables in areas too congested for fork lift trucks.

The solution:

A detachable caster adapter that can be easily fitted to welding tables in a minimum amount of space.

How it's done:

The schematic figure of the adapter shows a support saddle, designed to fit the leg of a welding table. A swiveled caster is secured to the caster platform which is in turn secured to the support saddle by means of a hinge. After the adapter is put into a position flush against the leg and base of the table, engagement of the caster is accomplished by a lever inserted into a cylinder (lever ring) welded to the caster platform. Pushing down on the lever simultaneously raises the

table and forces the caster into position. A hook on the support saddle will secure the caster platform once it is in position. It is recommended that a C-clamp be fixed to the leg and support saddle to secure the adapter to the table.

Notes:

1. The design of the support saddle can be easily modified to fit leg configurations of other pieces of heavy equipment.
2. This item is a modification of retractable permanently attached casters now in commercial use.
3. Documentation is available from:
Clearinghouse for Federal Scientific
and Technical Information
Springfield, Virginia 22151
Price \$3.00
Reference: TSP69-10164

(continued overleaf)

Patent status:

No patent action is contemplated by NASA.

Source: R. J. Mohr of
North American Rockwell Corporation
under contract to
Manned Spacecraft Center
(MSC-91215)