

May 1969

NASA TECH BRIEF



NASA Tech Briefs are issued to summarize specific innovations derived from the U.S. space program, to encourage their commercial application. Copies are available to the public at 15 cents each from the Clearinghouse for Federal Scientific and Technical Information, Springfield, Virginia 22151.

Helical Tape Forming Device

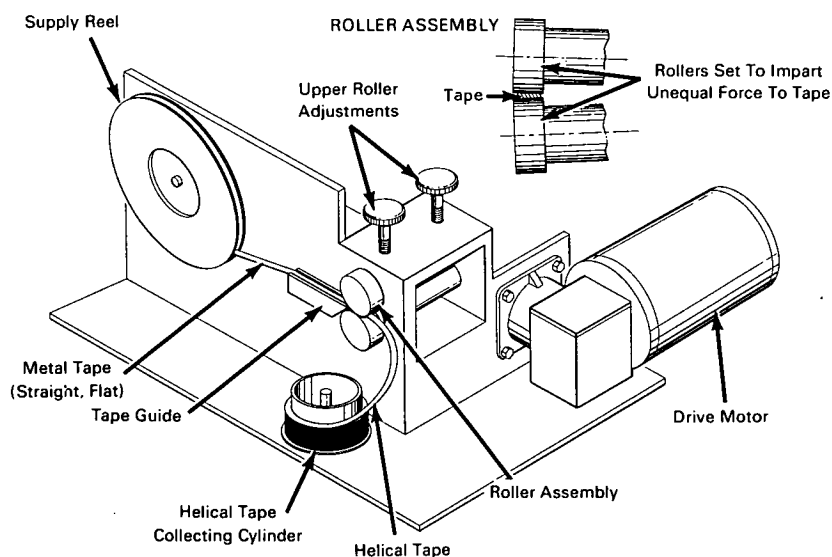

When thin metal tapes are wound into helical coils by the edge forming technique, the inner edge of the tape tends to buckle and corrugate. As coil diameters are decreased or tape width increased, corrugation distortion increases. Successful use of this method is limited to relatively thick metal tapes with a small width-to-thickness ratio.

A new technique has been developed which permits the forming of very thin metal tape or ribbon into a continuous flat wound helical coil. This technique features a device that is not limited to a minimum thickness or width-to-thickness ratio. The forming device imparts the desired circular shape to the normally flat tape by squeeze rolling it with an unequal force across its width. The tape passes through two rollers so adjusted that they form an angle that squeezes one edge of the tape to a greater degree than the other. Thus the tape, as it leaves the rollers, assumes a circular form since one edge of it has been stretched linearly due to the greater roller force imposed on it.

Diameter of the helical coil so formed is determined by the amount of differential force applied across the tape's width.

The forming rollers are of hardened steel ground to precise diameters. One roller is in a fixed position and is motor driven while the other is adjustable for controlling the angle of engagement with the tape.

Notes:

1. No further documentation is available.
2. Technical questions may be directed to:
Technology Utilization Officer
Goddard Space Flight Center
Greenbelt, Maryland 20771
Reference: B69-10137

Patent status:

No patent action is contemplated by NASA.

Source: Pleasant T. Cole and James E. Bush
(GSC-10830)
Category 05