

January 1969

Brief 69-10011

NASA TECH BRIEF



NASA Tech Briefs are issued to summarize specific innovations derived from the U.S. space program, to encourage their commercial application. Copies are available to the public at 15 cents each from the Clearinghouse for Federal Scientific and Technical Information, Springfield, Virginia 22151.

Nondispersive X-ray Emission Analysis for Geochemical Exploration

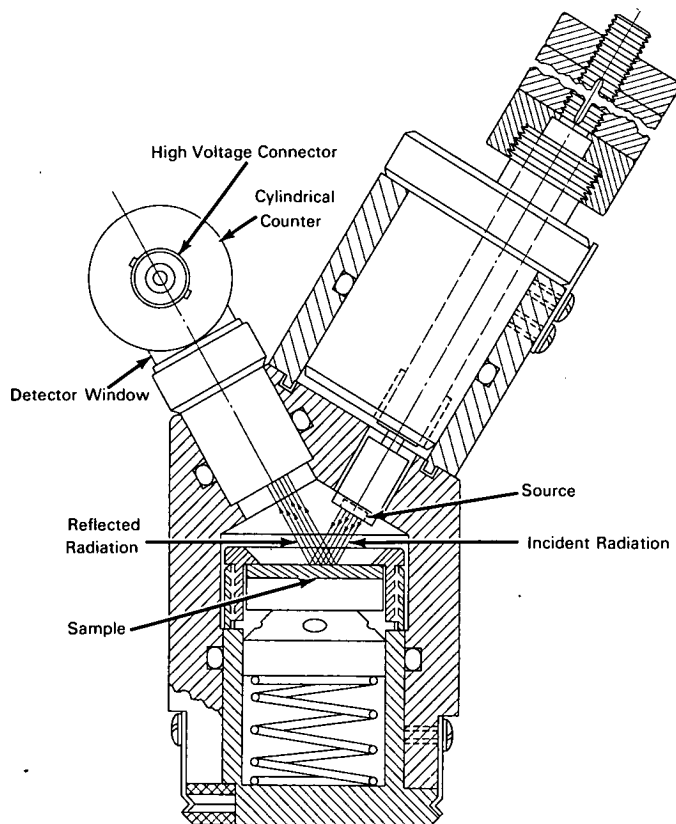

The problem:

To analyze X-ray pulse-height spectra in order to derive both qualitative and quantitative data from spectra measurements made with either proportional counters or solid state detectors. This problem was encountered in the space program in a study with the following objectives: (1) to obtain operational numbers to help an astronaut in lunar sample selection, and (2) to obtain geochemical information for mapping and preliminary surface analysis. Although the

lunar environment is not conducive to performing detailed geochemical analysis, a need exists for diagnostic tools to help the astronaut in selecting samples to be returned to laboratories for comprehensive studies. The requirements for these tools range from the geochemical parameters to be tested, and optimum instruments to be employed, to the data acquisition and processing in real time. Up to this time, only extremely simple analyses have been possible using a nondispersive system.

The solution:

An X-ray spectroscopy method, which uses simple, lightweight, and rugged X-ray fluorescence units for field exploration. The method can be used for both quantitative and qualitative analyses on complex chemical systems. This nondispersive X-ray emission technique allows relatively simple "in situ" analysis. The device used is portable, of simple and rugged construction, and of minimal space and power requirements. The X-ray spectra can be effectively excited by radioactive isotope sources.

A computer program has also been developed for data reduction and processing permitting rapid semi-quantitative assay of terrestrial geochemical samples.

How it's done:

The above figure shows the simple instrumentation used in laboratory analysis. The apparatus consists of a radioactive source, a means for holding the sample, a proportion detector, and an inlet for introducing helium into the chamber. Although a slight vacuum is desired, the helium serves primarily to preserve the alpha source window. The samples to be analyzed can be introduced as powders, briquets, or small flat sections of rock. In the program, attention was directed to the common rock-forming elements such as Mg, Al, Si, K, Ca, and Fe. The characteristics of K X-rays emitted by the majority of these elements range from 3Å to 12Å.

Radioactive sources are used since they are small, require no power, and are extremely reliable. These sources with relatively low output generate adequate X-ray spectra in minutes. Beta sources, bremsstrahlung sources, K capture X-ray sources, and alpha emitters have been used in X-ray emission analyses, but alpha sources prove best for light element analysis.

The source holder, illustrated below, holds a Cm²⁴² source of 15 mCi deposited by coating on a stainless steel foil. The window is 0.005-inch aluminum.

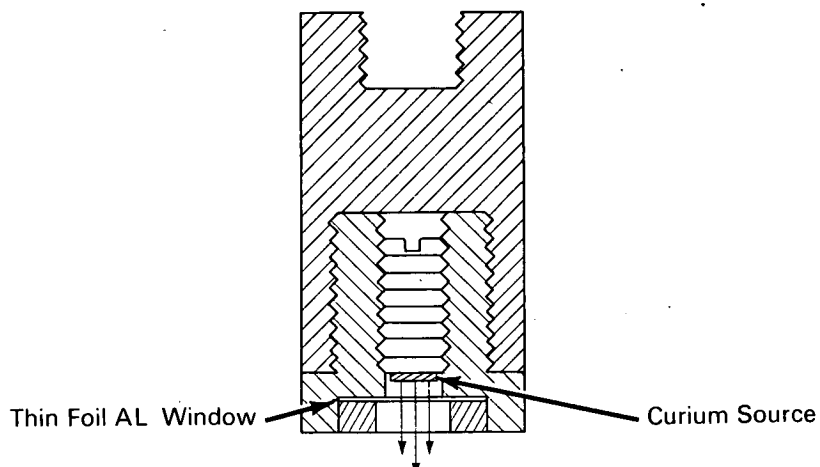

The detector is a thin-window proportional counter, either flow or sealed. With flow counters, one can work easily with 0.001-inch Be or 0.00025-inch mylar. The detector resolution in this study was of the order of 17% for Fe⁵⁵. The electronic arrangement was conventional, consisting of a charge sensitive preamplifier feeding a high quality multichannel analyzer. Although greater capabilities were available, 256 channels of the analyzer were sufficient. Data readout was on perforated tapes, which were then converted to punch cards for computer processing.

Results were compared to calibration curves and agreement was quite satisfactory for a first cut chemical analysis. Useful chemical values can be obtained satisfying the goals for a lunar geochemical exploration device.

Notes:

1. This information may be of interest to persons and organizations concerned with soil and geochemical analyses.
2. Documentation for the innovation is available from:

Clearinghouse for Federal Scientific
and Technical Information
Springfield, Virginia 22151
Price \$3.00
Reference: TSP69-10011

Patent status:

No patent action is contemplated by NASA.

Source: J. I. Trombka and I. Adler
of the Laboratory for Theoretical Studies
and R. Schmadebeck and R. Lamothe
of Melpar, Inc.
under contract to
Goddard Space Flight Center
(GSC-10568)