

NASA TECH BRIEF

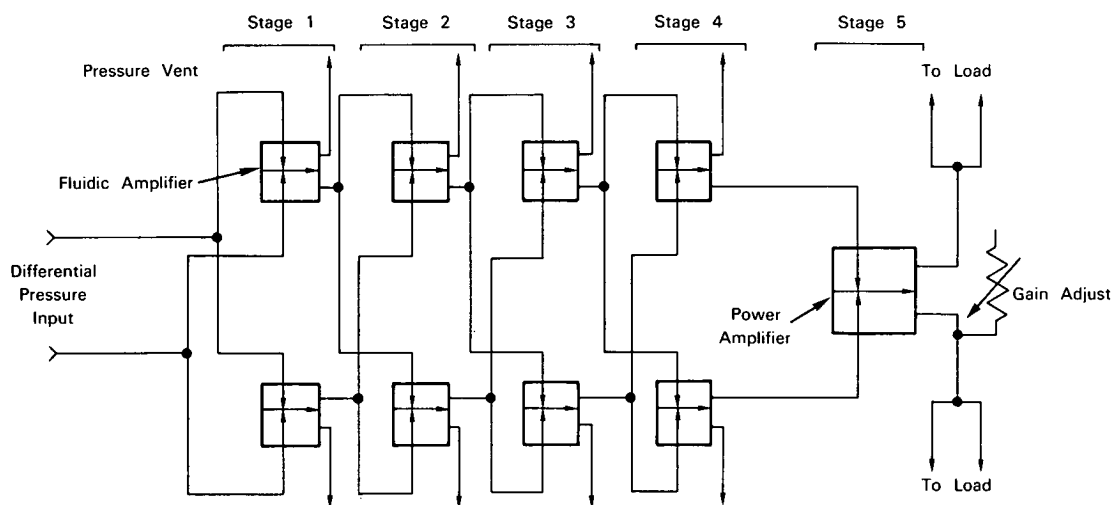

NASA Tech Briefs are issued to summarize specific innovations derived from the U.S. space program, to encourage their commercial application. Copies are available to the public at 15 cents each from the Clearinghouse for Federal Scientific and Technical Information, Springfield, Virginia 22151.

Fluidic Analog Amplifier



A five-stage, high-gain, push-pull fluidic amplifier has been designed to provide increased range and improved linearity compared to previous fluidic amplifiers.

A differential pressure from a pressure source (e.g., a fluidic transducer or control element) supplies the input to a pair of beam-deflection-type fluidic amplifiers in the first stage. Each amplifier, with one output vented to ambient and arranged in parallel with another amplifier in the succeeding stage, supplies an input to that stage. In this manner, the pressure signal is amplified through the first four stages. The output of the fourth stage drives the power amplifier comprising the fifth stage. An applied load is driven by the differential pressure output from the power amplifier. The pressure gain (ratio of output pressure

differential to input pressure differential) is approximately 74 for the five stages.

Notes:

1. This fluidic amplifier was designed to operate in conjunction with the fluidic transducer described in Tech Brief 68-10537. It should have general application in fluid-process control systems.
2. Documentation is available from:
 Clearinghouse for Federal Scientific and Technical Information
 Springfield, Virginia 22151
 Price \$3.00
 Reference: B68-10538

(continued overleaf)

Patent status:

Inquiries about obtaining rights for the commercial use of this invention may be made to NASA, Code GP, Washington, D.C. 20546.

Source: C.P. McKenzie
of Martin-Marietta Corporation
under contract to
Electronics Research Center
(ERC-10102)