

December 1968

Brief 68-10437

NASA TECH BRIEF



NASA Tech Briefs are issued to summarize specific innovations derived from the U.S. space program, to encourage their commercial application. Copies are available to the public at 15 cents each from the Clearinghouse for Federal Scientific and Technical Information, Springfield, Virginia 22151.

Two-Way Digital Driver/Receiver Uses One Set of Lines

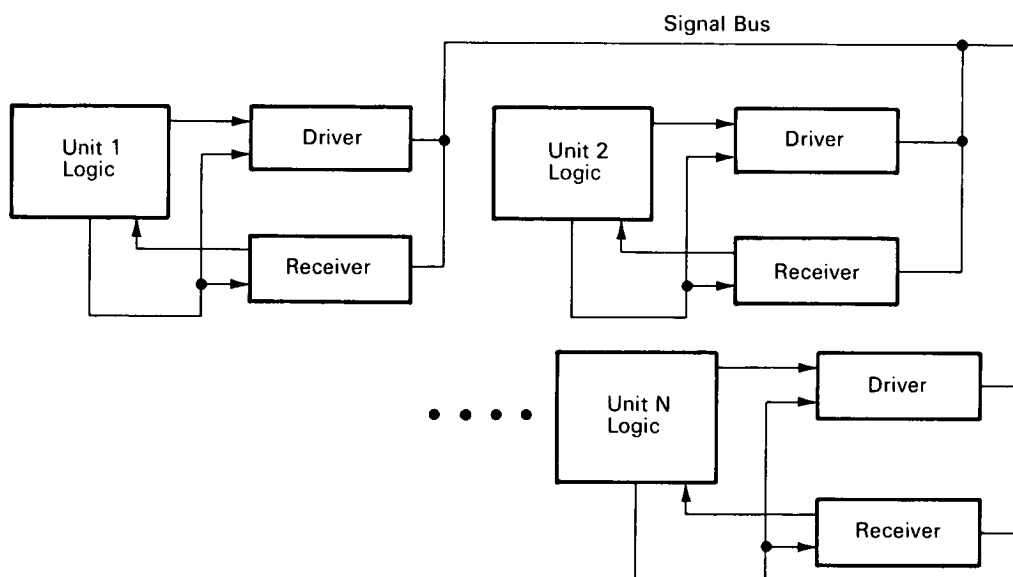

A two-way (bilateral) digital driver/receiver system using MOS circuits has been designed for a multi-processing computer having several subsystems at relatively close locations. Parallel data transfer between several locations has required considerable duplication of equipment and multiple communication lines. The new system requires only a single set of communication lines between subsystems, thus achieving lower cost with increased reliability.

The basic configuration of the system is illustrated in the block diagram. Each logic unit is associated with a driver and receiver for each word bit. The logic unit sends request signals on individual lines to other logic units, which then control the appropriate drivers and receivers. The receivers incorporate MOS devices, which are of sufficiently high impedance, to permit the use of one signal bus.

Note:

Inquiries concerning this system may be directed to:
 Technology Utilization Officer
 Electronics Research Center
 575 Technology Square
 Cambridge, Massachusetts 02139
 Reference: B68-10437

Patent status:

Inquiries about obtaining rights for the commercial use of this invention may be made to NASA, Code GP, Washington, D.C. 20546.

Source: G. J. Burnett and A. F. Pfeifer
 of North American Rockwell Corporation
 under contract to
 Electronics Research Center
 (ERC-10055)
 Category 01