

NASA TECH BRIEF

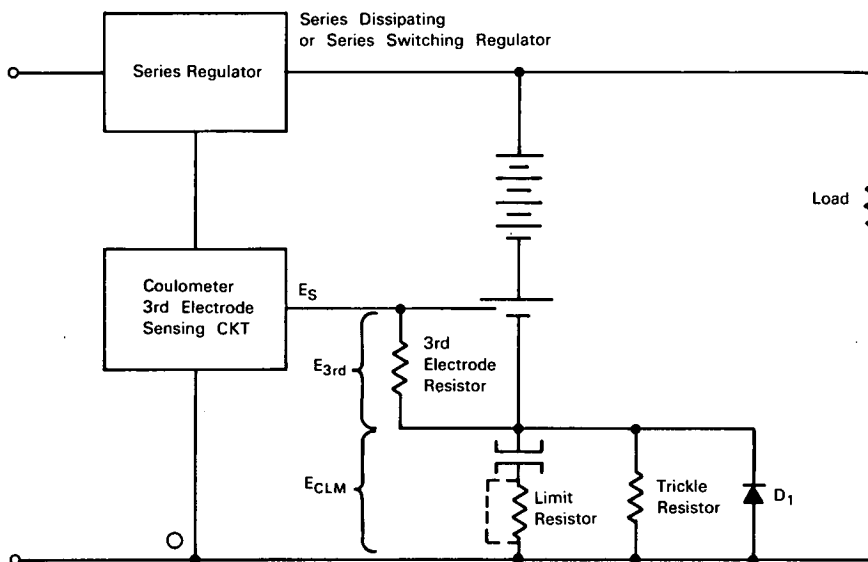

NASA Tech Briefs are issued to summarize specific innovations derived from the U.S. space program, to encourage their commercial application. Copies are available to the public at 15 cents each from the Clearinghouse for Federal Scientific and Technical Information, Springfield, Virginia 22151.

Charge Control of Nickel-Cadmium Batteries by Coulometer and Third Electrode Method



In the charge control of nickel-cadmium batteries that are frequently changed from a charge to a discharge condition, prior methods have left much to be desired. Constant current charging is slow because the charge current rate is limited by the safe overcharge current for battery and system. Because of the low charge currents and the limited time for recharging, only a fraction of the battery ampere-hour capacity is available during discharge. Such conditions are experienced by an orbiting satellite. Constant potential charging suffers from the nickel-cadmium battery's voltage characteristic of temperature dependency. The charge current is limited only by the solar array capability, the battery accepting all available current until the selected voltage is reached. A faster charge is possible with this method but the temperature-dependent voltage of the battery must be "tracked"

by the charger. Because of this voltage characteristic, the charge voltage must be precisely regulated to prevent excessive overcharge. An additional disadvantage is that failure of any one cell due to a short may be catastrophic to the battery. Coulometer control alone provides an abrupt signal when the ampere-hours removed during discharge have been replaced. Because a nickel-cadmium battery is only 85% to 90% efficient, the battery is not fully charged when this signal occurs and additional charging is required. Third electrode charge control alone regulates overcharge by sensing the oxygen partial pressure within a battery cell and providing a signal proportional in amplitude to this pressure. The method suffers from slow response time in applications where short discharge periods (30 minutes or less) are encountered.

(continued overleaf)

The figure illustrates a combined coulometer/third electrode control circuit for a nickel-cadmium battery including at least one cell of the third electrode type. The coulometer/third electrode sensing circuit controls the series regulator as necessary to maintain the sensing voltage at the preset sensing level. Assume that the sensing circuit is designed for 0.5 volts at sensing lead (E_s), where E_s is the sum of E_{CLM} and E_{3rdel} . If the third electrode voltage plus the coulometer voltage reaches 0.5 volts the sensing circuit reduces the drive signal to the series regulator as necessary to maintain the voltage (E_s) at 0.5 volts. If the third electrode voltage plus the coulometer voltage is less than 0.5 volts then the series regulator is full "on" delivering available current to the battery. When the ampere-hours passed through the coulometer on discharge has been replaced, the coulometer voltage will increase rapidly toward 0.5 volts. With 0.5 volts across the coulometer (the coulometer looks like an open circuit when fully "set") the battery current is then determined by the trickle resistor. In effect the voltage (E_s) is regulated at 0.5 volts by the regulator once the coulometer is "set". The battery trickle current is then related to the ohmic value of the trickle resistor. The higher the resistance value the lower the trickle charge rate, and conversely, the lower the resistance the higher the trickle charge rate.

A trickle resistor selected so that moderate trickle rates are maintained allows the battery to continue charging and go into overcharge at a safe rate as the third electrode signal begins to increase. An increasing third electrode signal indicates the battery is fully charged and further charging is unnecessary. Since the voltage (E_s) is being regulated at 0.5 volts the battery trickle rate is further decreased. Now the third electrode signal is the predominating signal making up (E_s) and the minimum trickle charge rate is determined by the value of "R" selected for the third electrode resistor. This low trickle rate is dictated by the battery requirements for various orbital conditions and may be selected to minimize heat generation and pressure build up due to excessive overcharge.

Notes:

1. No further documentation is available.
2. Questions concerning this invention may be directed to:

Technology Utilization Officer
Goddard Space Flight Center
Greenbelt, Maryland 20771
Reference: B68-10431

Patent status:

Inquiries about obtaining rights for the commercial use of this invention may be made to NASA, Code GP, Washington, D.C. 20546.

Source: John Paulkovitch and Floyd Ford
(GSC-10487)