



# AEC-NASA TECH BRIEF



AEC-NASA Tech Briefs describe innovations resulting from the research and development program of the U.S. AEC or from AEC-NASA interagency efforts. They are issued to encourage commercial application. Tech Briefs are published by NASA and may be purchased, at 15 cents each, from the Clearinghouse for Federal Scientific and Technical Information, Springfield, Virginia 22151.

## High Resolution Ge(Li) Spectrometer Reduces Rate-Dependent Distortions at High Counting Rates

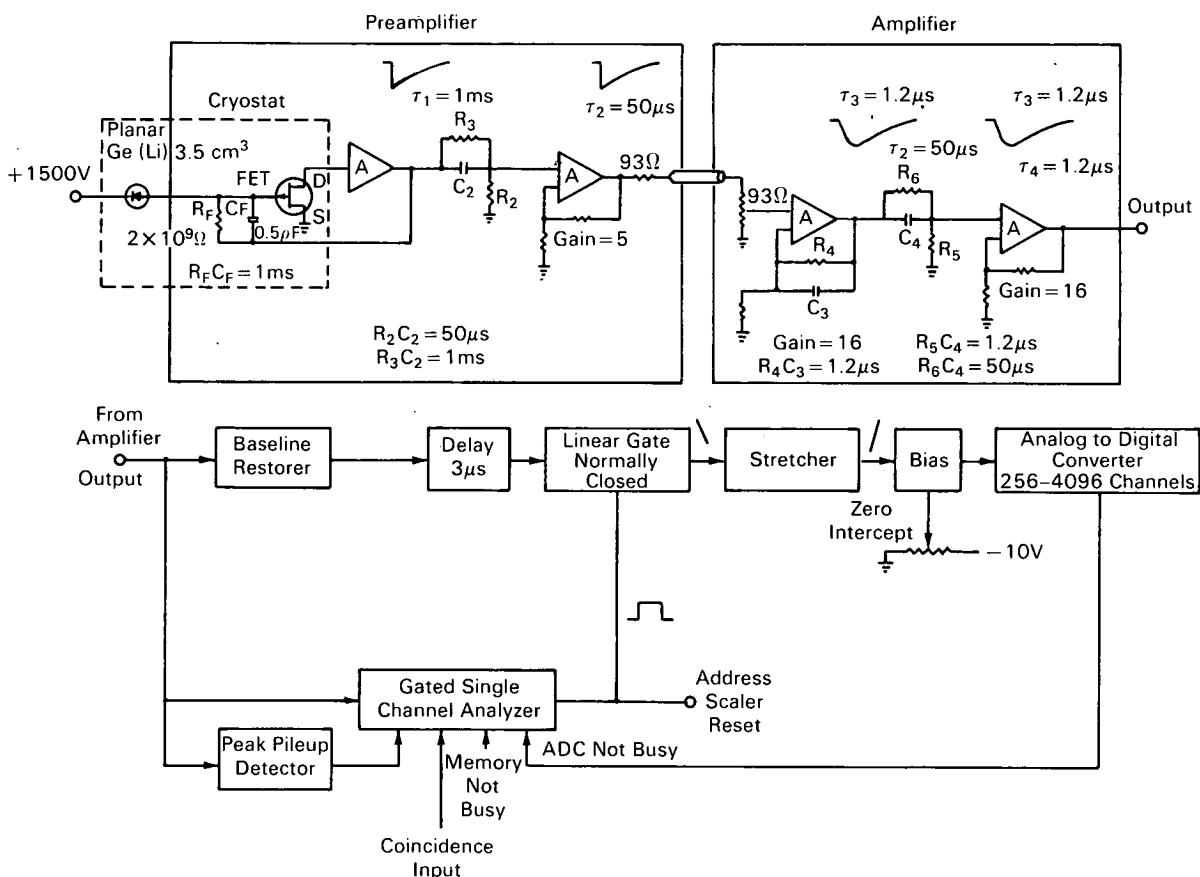

### The problem:

To obtain high resolution at high counting rates in a Ge(Li)  $\gamma$ -ray spectrometer. Previously, spectral distortions occurred at rates above a few thousand pulses/sec due to pulse undershoot, baseline shift, and pulse pileup, thus masking the spectrometer resolving power.

### The solution:

A modified spectrometer system with a low-noise preamplifier that reduces rate-dependent distortions at high counting rates. Pole-zero cancellation is used to minimize pulse undershoots due to multiple time constants; baseline restoration is used to further improve resolution and prevent spectral shifts; pulse

(continued overleaf)

shape discrimination and baseline discrimination are used to reject pileup pulses. The system resolution is nearly rate-dependent for counting rates up to 25,000 counts/sec.

#### How it's done:

Modifications contributing most significantly to high resolution at high counting rates are concentrated within the amplifying chain and the pulse height encoding system. A simplified schematic of the detector, preamplifier, and amplifier is shown in the figure. The detector used is a 3.5 cm<sup>3</sup>, 13 mm thick lithium-drifted planar germanium diode housed in a cryostat and cooled to 77°K. The preamplifier consists of two sections: a charge integrator and an output driver. The integrator input stage is a field effect transistor (FET) which is direct-coupled to the detector and also cooled to 77°K. The amplifier consists of two 3-transistor feedback loops with a gain of 16 per loop.

Pulses from the integrating section of the preamplifier rise in 50–150 nsec, as determined by the detector collection time, and decay exponentially with a time constant  $R_F C_F$ . The pulses are differentiated in the preamplifier with  $R_2 C_2$ , and once more in the amplifier with  $R_5 C_4$ . To prevent undershoots due to the multiple differentiations, pole-zero cancellation is obtained from  $R_3 C_2$  and  $R_6 C_4$ .

To prevent rate effects and drift of the dc level at the output of the amplifier from affecting the baseline, a baseline restorer is used which superimposes each pulse on a stable dc level. The baseline restorer also acts as a nonlinear high-pass filter, thus improving the system signal-to-noise ratio.

Prior to encoding, a pulse is inspected for pileup. A baseline discriminator in the gated single channel analyzer is triggered when an input pulse exceeds the noise level ( $\approx 50$  mV). Once triggered, the discriminator is held inoperative while the signal exceeds the noise level. The discriminator strobes an internal gate and, when all gating conditions are satisfied, a single channel analyzer output is generated. When a second

pulse occurs before the tail of the first pulse has returned to within 50 mV of the baseline, the discriminator is not triggered, and thus "tail pileup" pulses are rejected. A pulse starting on the baseline rather than on the tail of a previous pulse may also have a pulse superimposed on the leading edge and thus distorted by "peak pileup". A peak pileup detector produces differentiated zero-crossing pulses, and since the zero-crossing of pileup pulses occur later than that of undistorted pulses, the pileup pulses are readily gated out in the single channel analyzer.

When an undistorted pulse is detected, the linear gate is opened and the selected pulse is processed in the analog-to-digital converter and stored as digital data.

#### Notes:

1. Additional details may be found in *Rev. Sci. Instr.*, vol. 38, no. 6, p. 725–730, June 1967.
2. Inquiries concerning this innovation may be directed to:

Office of Industrial Cooperation  
Argonne National Laboratory  
9700 South Cass Avenue  
Argonne, Illinois 60439  
Reference: B68-10420

Source: M.G. Strauss, I.S. Sherman,  
R. Brenner, S. J. Rudnick,  
R. N. Larsen, and H.M. Mann  
of the Electronics Division  
(ARG-10144)

#### Patent status:

Inquiries about obtaining rights for commercial use of this innovation may be made to:

Mr. George H. Lee, Chief  
Chicago Patent Group  
U.S. Atomic Energy Commission  
Chicago Operations Office  
9800 South Cass Avenue  
Argonne, Illinois 60439