

November 1968

Brief 68-10404

NASA TECH BRIEF



NASA Tech Briefs are issued to summarize specific innovations derived from the U.S. space program, to encourage their commercial application. Copies are available to the public at 15 cents each from the Clearinghouse for Federal Scientific and Technical Information, Springfield, Virginia 22151.

Design Concept for Nonarcing Electrical Connector

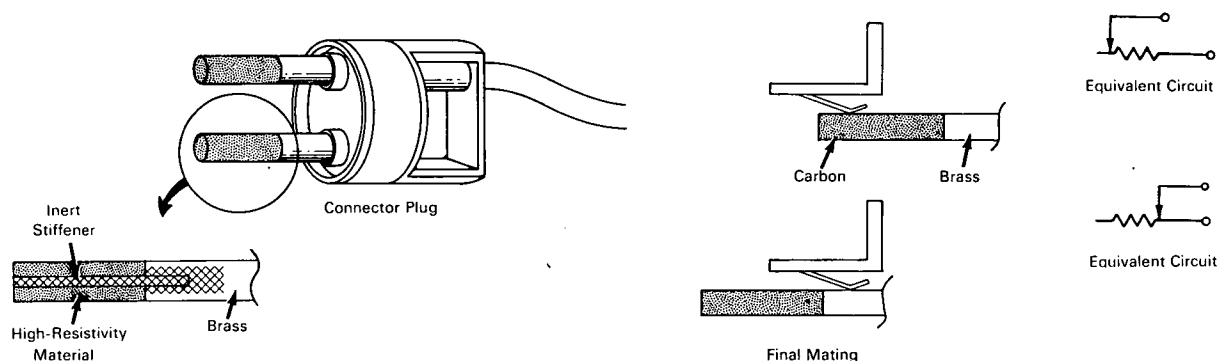

A connector plug, as illustrated in the conceptual sketches, will automatically minimize arcing during mating and demating. This plug incorporates a high-resistivity outer sheath, such as a carbon rod with an appropriate inert binder, as an extension to the regular pin contact. As the plug is inserted into a receptacle, the high-resistivity sheath limits the current to below the arcing level. On continuing the insertion, less and less of the sheath is placed in series with the line current, until with the "bottoming" of the brass base the circuit is completed and maximum current flows. On withdrawal of the plug, the process is reversed so that arcing is minimized (minimum current flows) at the instant of demating.

The carbon rod can be made very hard and would be machinable. However, since such a rod has very little shear strength, an inert stiffener would be required as shown in the sketch.

This connector would be useful in atmospheres containing explosive or combustible gases or vapors. It would also reduce erosion at the contact surfaces in cases where mating and demating are performed frequently.

Note:

This device is only in the conceptual stage; neither a model nor a prototype has been built as of the date of this Tech Brief.

Patent status:

No patent action is contemplated by NASA.

Source: R. E. Holmen
of Douglas Aircraft Company
under contract to
Marshall Space Flight Center
(MFS-14937)

Category 01