

AEC-NASA TECH BRIEF

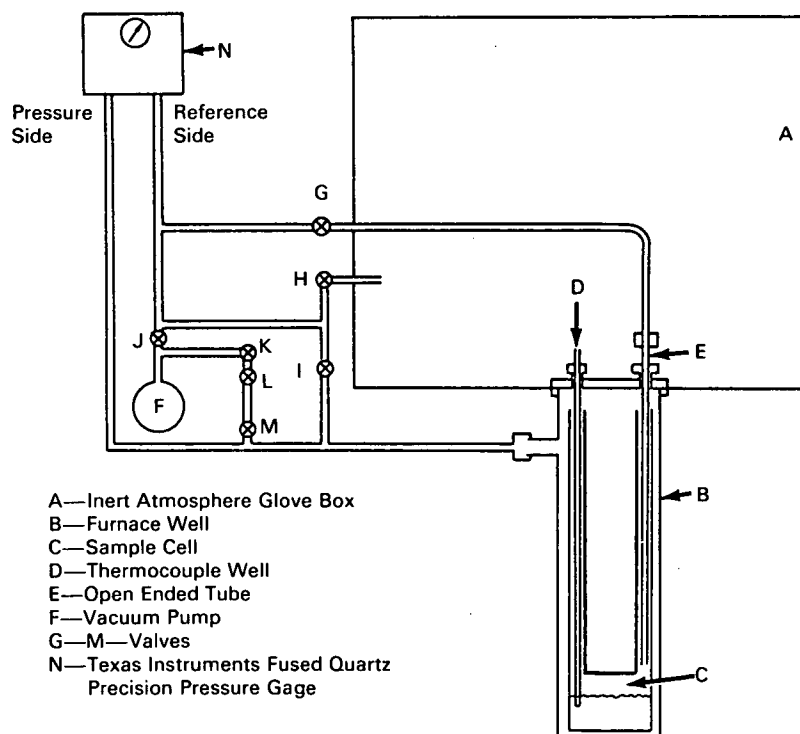

AEC-NASA Tech Briefs describe innovations resulting from the research and development program of the U.S. AEC or from AEC-NASA interagency efforts. They are issued to encourage commercial application. Tech Briefs are published by NASA and may be purchased, at 15 cents each, from the Clearinghouse for Federal Scientific and Technical Information, Springfield, Virginia 22151.

Quasi-Static Vapor Pressure Measurements on Reactive Systems in Inert Atmosphere Box



Application:

The apparatus permits vapor pressure measurements (and all preparatory operations) to be made on air-sensitive systems in an inert atmosphere glove box. Once the apparatus is loaded with the sample and all connections made, all measuring operations may be performed outside the box. The method is advantageous if the system must be isolated or removed from the experimenter.

Description:

The apparatus is, in effect, a single-tube adaptation of the double-tube quasi-static technique. A true

single-tube design would help minimize sample composition changes caused by holdup in the condensation zone. In such a design the thermocouple well could be welded into the sample cell.

The sample temperature remains steady and uniform during a measurement. At the start of a measurement, the box, including the reference side of the gauge, is full of helium at a pressure greater than the vapor pressure of the sample. With valves H, I, and J closed and G open, pressure is reduced in steps by operating valves K, L, and M. The volume between valves K and L is smaller than that between valves L

(continued overleaf)

and M, so a choice of pressure decrement is available, depending on the sequence of operation of valves K, L, and M.

During the decremental pressure changes, the pressure gauge functions as a differential pressure detector. When the first long-lasting pressure difference is established (30 seconds or more), the pressure has been reduced to, or slightly below, the vapor pressure of the sample. At this point, valve G is closed; valves H, I, and K remain closed; and valve J is opened to evacuate the reference side of the gauge. This done, the pressure indicated on the pressure gauge is recorded as the vapor pressure of the sample at the given temperature.

To break vacuum in the system, valve J is closed and valve H opened slowly to admit helium from the glove box until the gauge reads zero. Pressures throughout the system now have been equalized. Valves G and I are opened and bleeding is continued slowly with valve H. In this way, helium is admitted to both arms of the sample cell and to tube E to prevent sweeping vapor out of the cell.

Notes:

1. Details are available in *Review of Scientific Instruments*, vol. 37, no. 6, p. 717-719, June 1966.
2. Additional information may be obtained from:
Office of Industrial Cooperation
Argonne National Laboratory
9700 South Cass Avenue
Argonne, Illinois 60439
Reference: B68-10236

Source: A. K. Fischer
Chemical Engineering Division
(ARG-90142)

Patent status:

Inquiries about obtaining rights for commercial use of this innovation may be made to:

Mr. George H. Lee, Chief
Chicago Patent Group
U.S. Atomic Energy Commission
Chicago Operations Office
9800 South Cass Avenue
Argonne, Illinois 60439