



# AEC-NASA TECH BRIEF



AEC-NASA Tech Briefs describe innovations resulting from the research and development program of the U.S. AEC or from AEC-NASA interagency efforts. They are issued to encourage commercial application. Tech Briefs are published by NASA and may be purchased, at 15 cents each, from the Clearinghouse for Federal Scientific and Technical Information, Springfield, Virginia 22151.

## Tunnel Diode Circuit Used as Nanosecond-Range Time Marker

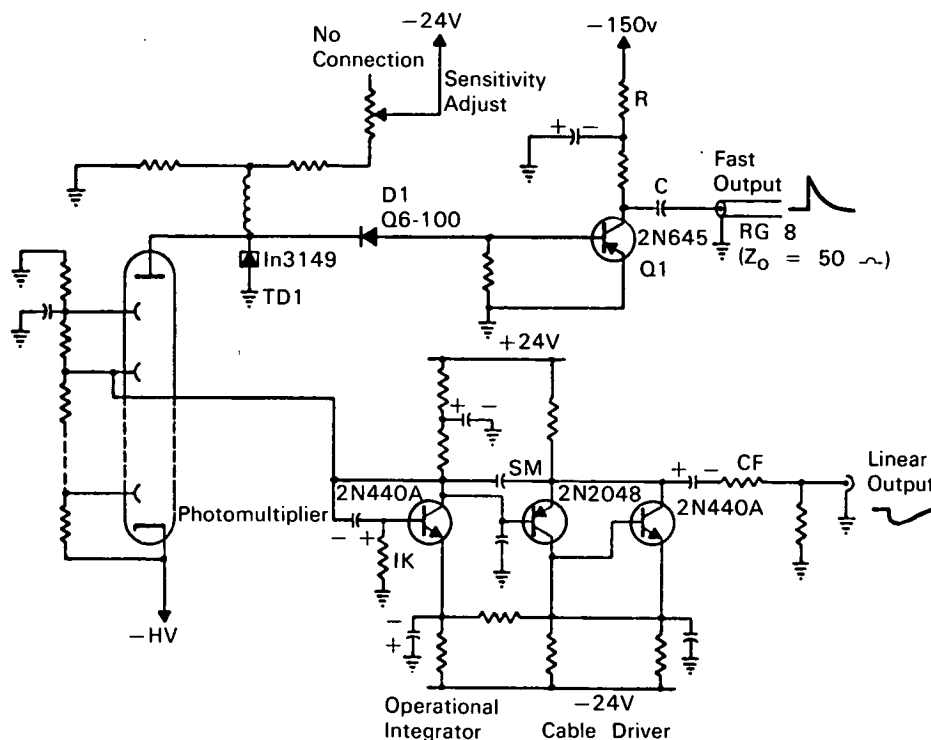

PREAMPLIFIER CIRCUIT WITH FAST OUTPUT (TOP) AND LINEAR OUTPUT (BOTTOM).

### The problem:

To determine the time at which an event occurs in a scintillation crystal by the use of a relatively simple circuit. A commonly used method obtains this information by amplifying a partially integrated photomultiplier (PM) tube signal which triggers a voltage discriminator. The use of the voltage discriminator technique, however, results in timing uncertainties due to rise-time variations in the partially integrated PM output pulse applied to the discriminator thresh-

old. Rise-time amplitude variations in the discriminator input signal produce a discriminator output pulse "walk" or "jitter". Other PM output pulse rise-time variations are caused by (1) the statistical production of photoelectrons at the PM cathode, and (2) by the time spread required for electron multiplication through the PM tube.

### The solution:

A simple tunnel diode time marker circuit capable of triggering at voltages as low as the noise level of

(continued overleaf)

a 10-stage PM tube. The circuit marks the time-occurrence of the first few photoelectrons emitted from a PM-tube cathode, thus reducing the output-pulse timing uncertainty.

**How it's done:**

The unintegrated PM-tube anode current pulse triggers the tunnel diode (TD1) current discriminator, and provides a pulse of fixed amplitude and width. The TD1 output pulse is applied to transistor Q1 operating in the avalanche mode through dc isolation diode D1. Under quiescent conditions, Q1 conducts approximately one-half the current necessary to cause an avalanche breakdown. When TD1 triggers, the Q1 collector potential drops in the avalanche mode from the quiescent value of 100 V to ground. The 100 V pulse is coupled to the output through C, a 20 pf capacitor. The capacitor and the low impedance of the line differentiate the pulse. The fast output pulse can thus be used as a fast timing signal produced simultaneously with the detection of the first few PM-tube photoelectrons.

**Notes:**

1. The differentiated output pulse amplitude is varied by varying the size of the coupling capacitor C.

2. Additional information is contained in *Nuclear Instruments and Methods*, vol. 32, p. 168-170, 1965.
3. Inquiries concerning this innovation may be directed to:

Office of Industrial Cooperation  
Argonne National Laboratory  
9700 South Cass Avenue  
Argonne, Illinois 60439  
Reference: B68-10173

Source: R. N. Larsen, Electronics Division,  
and E. B. Shear, Physics Division  
(ARG-90164)

**Patent status:**

Inquiries about obtaining rights for commercial use of this innovation may be made to:

Mr. George H. Lee, Chief  
Chicago Patent Group  
U.S. Atomic Energy Commission  
Chicago Operations Office  
9800 South Cass Avenue  
Argonne, Illinois 60439