

April 1968

# NASA TECH BRIEF



NASA Tech Briefs are issued to summarize specific innovations derived from the U.S. space program, to encourage their commercial application. Copies are available to the public at 15 cents each from the Clearinghouse for Federal Scientific and Technical Information, Springfield, Virginia 22151.

## Shallow Grooves in Journal Improve Air Bearing Performance

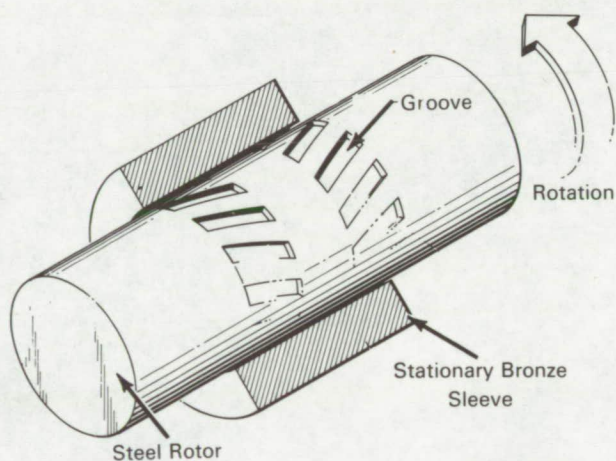

PARTIALLY GROOVED ROTOR

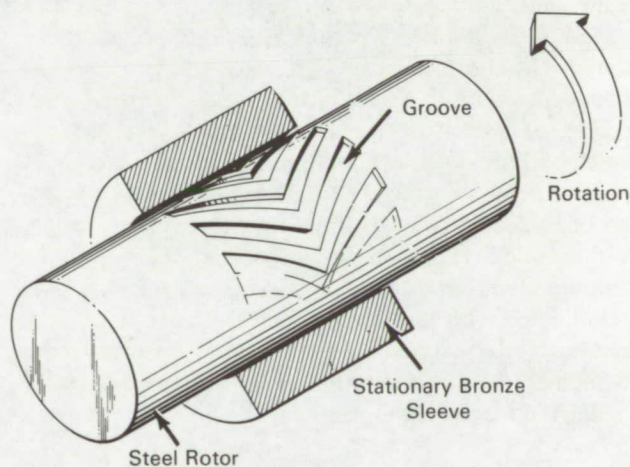

FULLY GROOVED ROTOR

Lightly loaded rotors (journals) running in gas-lubricated, plain journal bearings are inherently unstable. Tangential film forces, which predominate under light load conditions, cause the rotor to precess or "whirl" about the bearing center. The frequency of this motion is approximately one-half that of the rotational speed and is generally referred to as half-frequency whirl. This is a self-excited instability which produces an outward spiraling of the rotor when speed is increased. If contact of rotor and bearing occurs, a destructive seizure usually results.

A number of self-acting bearing designs which have been studied exhibit somewhat stable operating characteristics. These designs shape the bearing surface to create artificial fluid-film wedges in the absence of any applied radial load, and radial restoring forces are generated which tend to keep the journal from whirling. These designs achieve a certain degree of stability, but at the expense of load capacity. The helical- or herringbone-grooved journal or rotor

shows the most promise of stable operation, with no sacrifice in load capacity. Shallow grooves formed in a herringbone pattern act like a pump when the rotor turns, and air is pumped from the bearing ends toward the middle. The pressure distribution that results is similar to that obtained in a hydrostatic gas bearing. Attitude angles in herringbone grooves and hydrostatic bearings are small and radial restoring forces high. The difference, however, is that the pressure in a herringbone bearing increases significantly with increasing speed.

Rotors, 1 1/2 inches in diameter by 12 1/4 inches long, with herringbone grooves having varying geometries were tested to speeds up to 60,830 rpm. The rotors were mounted in cylindrical bronze sleeves and operated in a vertical position to negate gravity forces. The dynamic attitude of the rotors in the bearings was continuously monitored and whirl onset speeds recorded. Different sets of bronze sleeves were used to determine the effects of clearance on whirl

(continued overleaf)

onset speeds. No external load was applied to the bearings. Test results in low- and high-clearance sleeves indicated that half-frequency whirl is most affected by the radial clearance. Five partially grooved rotors ran stably to maximum speeds of 55,000 to 59,000 rpm when clearances ranged from 370 to 500 microinches. When clearances were increased from 550 to 710 microinches, the five rotors experienced half-frequency whirl. Limited test results with two rotors having identical groove geometry, except for groove length and comparable clearances, indicate that a fully grooved bearing is more stable than a partially grooved one.

**Note:**

Technical details may be obtained from:  
Technology Utilization Officer  
Lewis Research Center  
21000 Brookpark Road  
Cleveland, Ohio 44135  
Reference: B68-10134

**Patent status:**

No patent action is contemplated by NASA.

Source: R. E. Cunningham,  
D. P. Fleming, and W. J. Anderson  
(LEW-10396)