

April 1968

Brief 68-10121

NASA TECH BRIEF



NASA Tech Briefs are issued to summarize specific innovations derived from the U.S. space program, to encourage their commercial application. Copies are available to the public at 15 cents each from the Clearinghouse for Federal Scientific and Technical Information, Springfield, Virginia 22151.

Circuit Enhances Vertical Resolution in Raster Scanning Systems

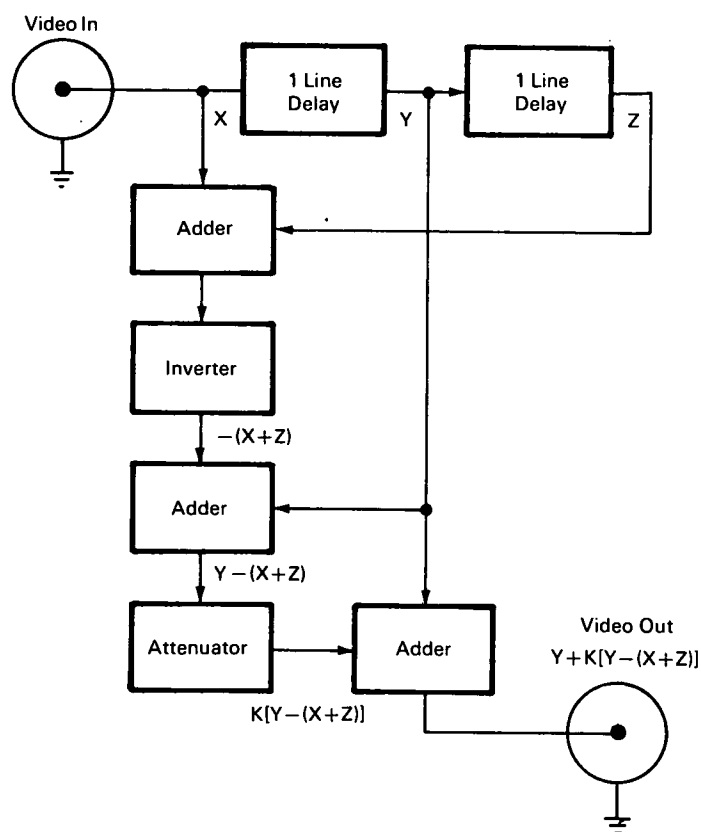

The circuit represented by the block diagram is designed to enhance vertical resolution in electron beam, raster scanning systems exhibiting aperture distortion in the vertical direction. A sensitized area (image) whose boundary lies more than one sweep-width away from the scan beam position produces a video output when the scan beam nears it. This effect produces vertical elongation in the reconstructed images of all sensitized areas on the surface

as well as smearing between vertically adjacent, closely spaced images.

The method used to compensate for the distortion and its attendant loss of resolution is based on a real-time comparison between the vertical characteristics of an image and its immediate future and past history. In the television raster system, video signals are delayed by exactly the horizontal scan period. Two such delay increments are used so that three com-

(continued overleaf)

plete (two delayed and one real-time) video lines are available simultaneously and are in horizontal synchronization. As indicated on the block diagram, the incoming video signals are delayed one horizontal period each by the delay lines. The resulting signals are X (undelayed), Y (delayed one period), and Z (delayed two periods). These signals are processed by sequential addition, inversion, and attenuation (attenuator constant typically less than 0.5) so that the video output becomes: $Y + K [Y - (X + Z)]$. Resolution enhancement is attained through contrast enhancement between closely vertically spaced images. This enhancement is achieved at the expense of some loss in contrast of vertically continuous images.

Notes:

1. In its present stage of development, the circuit is not suitable for vector/alphanumeric displays, because these require higher horizontal resolution than is now practicable with the circuit.

2. The basic concept of this circuit may be applied as a means of enhancing the signal-to-noise ratio as well as vertical resolution in raster scanning systems.
3. Technical details may be obtained from:
Technology Utilization Officer
Manned Spacecraft Center
Houston, Texas 77058
Reference: B68-10121

Patent status:

No patent action is contemplated by NASA.

Source: J. R. Greenwood, W. H. Alsofsky,
and O. M. Holley
of Philco-Ford Corporation
under contract to
Manned Spacecraft Center
(MSC-12123)

SF
RM. 3376
KSC HQS.
ALIN. AFKINS