

March 1968

Brief 68-10084

NASA TECH BRIEF



NASA Tech Briefs are issued to summarize specific innovations derived from the U.S. space program, to encourage their commercial application. Copies are available to the public at 15 cents each from the Clearinghouse for Federal Scientific and Technical Information, Springfield, Virginia 22151.

Gyrator-Type Circuits Replace Ungrounded Inductors

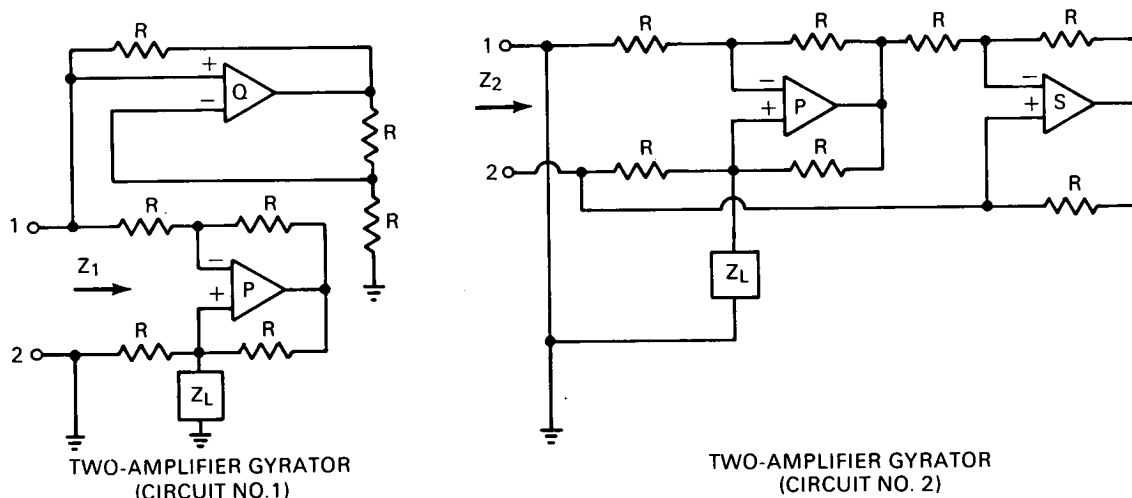

TWO-AMPLIFIER GYRATOR
(CIRCUIT NO. 1)

TWO-AMPLIFIER GYRATOR
(CIRCUIT NO. 2)

The problem:

To design an electronic circuit that does not use inductors, yet will perform the same function as one using inductors. The purpose is to permit complete microminiaturization of circuitry by integration of the components, since inductors having values in excess of a few microhenries are difficult, if not impossible, to integrate.

The solution:

Gyrator circuits using only transistors, capacitors, and resistors which can replace both grounded and ungrounded inductors. Circuits having effective inductances of hundreds of henries have been successfully built. Filters utilizing these circuits have achieved frequency responses closer to the ideal than circuits with real inductors.

How it's done:

Two gyrator circuits were designed using two operational amplifiers in each. Each can be used to simulate a grounded inductor. Normally, an ungrounded inductor would be replaced by two gyrators and a capacitor, for a total of four amplifiers in the circuit. However, when these two gyrators are combined and terminated with a capacitor, only three operational amplifiers are required.

Notes:

1. Additional details are contained in: *Application of a Gyrator-Type Circuit to Ungrounded Inductors*, by Gordon J. Deboo, IEEE Transactions on Circuit Theory, vol. CT-14, no. 1, p. 101-102, March 1967.
2. Another solution to the problem, based on a totally different design philosophy is given in NASA Tech Brief 66-10309, available from the Clearinghouse for Federal Scientific and Technical Information, Springfield, Virginia 22151; price \$0.15.

(continued overleaf)

3. Inquiries concerning these circuits may be directed to:

Technology Utilization Officer
Ames Research Center
Moffett Field, California 94035
Reference: B68-10084

Patent status:

This invention is owned by NASA, and a patent application has been filed. Royalty-free, nonexclusive licenses for its commercial use will be granted by NASA. Inquiries concerning license rights should be made to NASA, Code GP, Washington, D.C. 20546.

Source: Gordon J. Deboo
(XAC-10608)

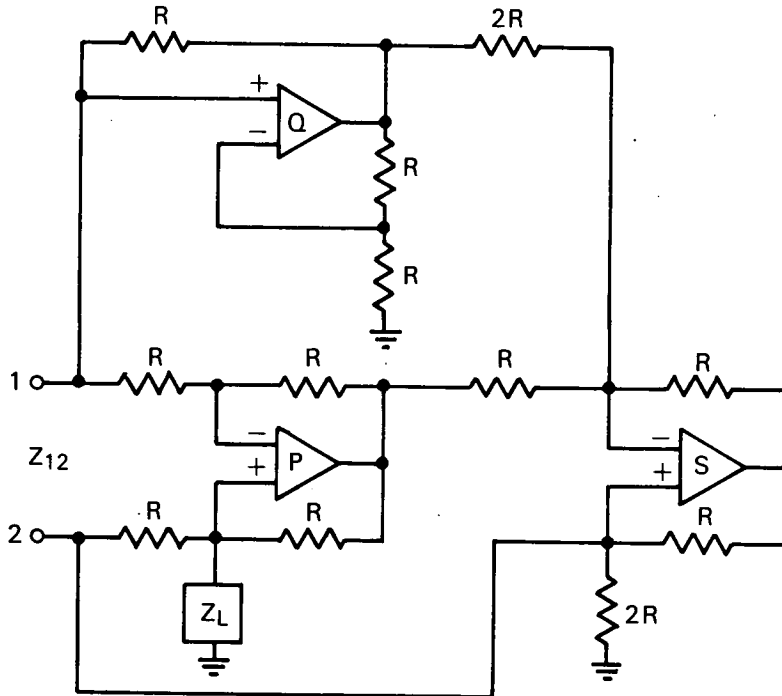

COMBINED GYRATOR CIRCUIT