

March 1968

Brief 68-10073

NASA TECH BRIEF



NASA Tech Briefs are issued to summarize specific innovations derived from the U.S. space program, to encourage their commercial application. Copies are available to the public at 15 cents each from the Clearinghouse for Federal Scientific and Technical Information, Springfield, Virginia 22151.

New Microelectronic Power Amplifier

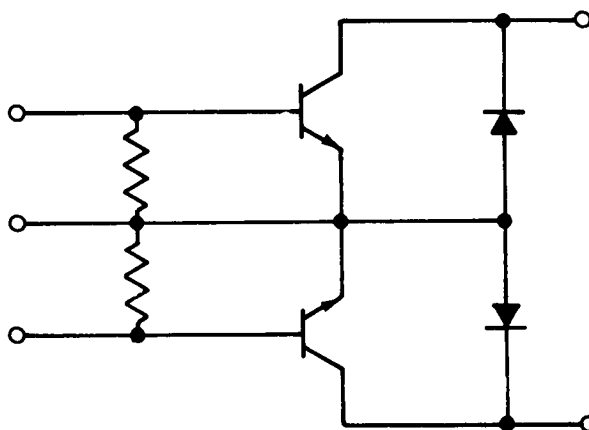

An integrated push-pull power amplifier has been fabricated on a chip of silicon measuring 0.250×0.450 inch. The power transistors are interdigitated, and occupy 80 percent of the area. The remaining 20 percent of the area is occupied by the resistors and diodes. The device is hermetically encapsulated in a beryllia flat package. Beryllia was chosen over other ceramics because of its high thermal conductivity, high electrical resistivity, and high dielectric strength. Although the amplifier was required to provide a nominal output of 10 amperes from an input current drive of 1 ampere, it is capable of current outputs several times greater than the nominal value. The dc supply is 28 volts. Operating temperature is from -55° to $+150^\circ\text{C}$.

A limited number of the devices were fabricated and tested for electrical performance under severe environmental conditions and were found to be satisfactory in all respects. Because of the small number tested, statistically significant data on reliability or mean time between failures are not available.

Notes:

1. This power amplifier is believed to be a significant development in silicon integrated devices.
2. The basic device should serve as a prototype for volume production in view of the large number of applications for push-pull power transistors for either switching or amplifying. The design provides flexibility for scaling either upward or downward depending on the power dissipation requirements.
3. Additional details may be obtained from:
Technology Utilization Officer
Marshall Space Flight Center
Huntsville, Alabama 35812
Reference: B68-10073

Patent status:

No patent action is contemplated by NASA.

Source: T. C. New
of Westinghouse Electric Corporation
under contract to
Marshall Space Flight Center
(MFS-13621)
Category 01