

# NASA TECH BRIEF

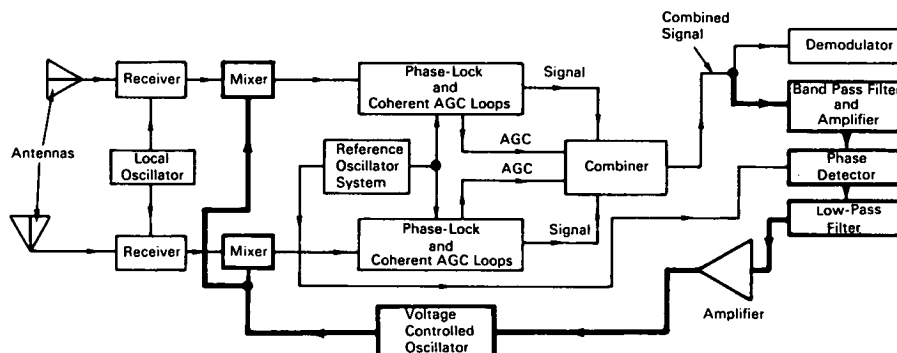

NASA Tech Briefs are issued to summarize specific innovations derived from the U.S. space program, to encourage their commercial application. Copies are available to the public at 15 cents each from the Clearinghouse for Federal Scientific and Technical Information, Springfield, Virginia 22151.

## Diversity RF Receiving System with Improved Phase-Lock Characteristics



An improved diversity receiving system automatically utilizes the combined output from its two independent receiving channels (with cross-polarized receiving antennas) in such a way as to increase the reliability of maintaining the requisite phase lock for optimum signal reception. This system is adapted for use with AM, PM, or narrow band FM signals.

The combined signal output from the two receivers is applied to a primary phase-lock loop (shown by heavier lines in the block diagram). In this loop, the phase of the combined signal is compared with the phase of a reference signal, and an error voltage proportional to the phase difference is developed. This error voltage is used to vary the frequency of a voltage controlled oscillator, which in turn has its output signal heterodyned with the input signal in each of the receiving channels. In this manner, the primary phase-lock loop permits the system to track changes common to both receiving channels so that frequency variations, such as those due to Doppler shifts, are followed. Two secondary phase-lock, coherent automatic gain control loops in the individual receiving channels compensate for differential signal changes in these channels, and thus assure the phase coherence necessary for optimum combining.

The primary phase-lock loop includes a phase detector which receives signals from the reference oscillator system; a band pass filter and amplifier; a voltage controlled oscillator connected to the phase detector via a low-pass filter and an amplifier; and two mixers connected to the two receiving channels.

### Note:

Inquiries concerning this system may be directed to:

Technology Utilization Officer  
Goddard Space Flight Center  
Greenbelt, Maryland 20771  
Reference: B68-10068

### Patent status:

This invention has been patented by NASA (U.S. Patent No. 3,348,152), and royalty-free license rights will be granted for its commercial development. Inquiries about obtaining a license should be addressed to NASA, Code GP, Washington, D.C. 20546.

Source: C. R. Laughlin, Jr. and V. J. Di Losa  
(XGS-01222)

Category 01