

J. Watson



NATIONAL AERONAUTICS AND SPACE ADMINISTRATION
WASHINGTON, D.C. 20546

TELS. WO 2-4155
WO 3-6925

**FOR RELEASE: TUESDAY A.M.
May 2, 1967**

RELEASE NO: 67-101

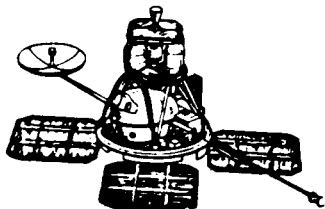

PROJECT: LUNAR ORBITER D
(To be launched no earlier
than May 4, 1967)

CONTENTS

GENERAL RELEASE-----1-7

LUNAR ORBITER PROJECT-----8-9

ORBITER SPACECRAFT CONFIGURATION-----10

 Camera System-----10-11

 Photo Taking Process-----11-12

 Photo Readout Process-----12-14

 Electrical Power System-----15

 Attitude Control System-----16-19

 Velocity Control System-----19-20

 Communications System-----21-22

 Temperature Control System-----22-23

LUNAR ORBITER TASKS-----24-25

 Lunar Photography-----25-27

 Selenodesy-----27-28

 Meteoroid Measurements-----28-29

 Radiation Measurements-----29

ATLAS-AGENA D LAUNCH VEHICLE-----30-31

DEEP SPACE NETWORK-----32-33

 Data Acquisition-----33

 Data Evaluation-----34

ATLAS-AGENA D/LUNAR ORBITER D MISSION-----35

 Countdown Events-----35

 Flight Events Summary-----36

 Launch Vehicle Flight-----37

 First Spacecraft Events-----38

 Lunar Orbit Injection-----39

LUNAR ORBITER AND ATLAS-AGENA TEAMS-----40-44

**P
R
E
S
S

K
I
T**

FACILITY FORM 602

N 67-23960
(ACCESSION NUMBER)

51
(PAGES)

(NASA CR OR TMX OR AD NUMBER)

(THRU)

(CODE)

31
(CATEGORY)

4/26/67



FOR RELEASE: TUESDAY A.M.'s
May 2, 1967

RELEASE NO: 67-101

LUNAR ORBITER D
SECOND MISSION
IN THREE WEEKS

The United States is preparing to launch a photographic laboratory spacecraft for the second automated spacecraft mission to the Moon within three weeks.

Lunar Orbiter D is scheduled for launch by the National Aeronautics and Space Administration within the period May 4 - 7. Surveyor III soft-landed on the Moon after its launch April 17.

Lunar Orbiter spacecraft are flown to continue the efforts made with Ranger and Surveyor flights to acquire knowledge of the Moon's surface. The first three Lunar Orbiter missions were in direct support of the Apollo and Surveyor lunar landing programs; they identified eight areas in which potential manned landing locations exist.

The fourth Orbiter mission will be a broad photographic survey of the entire front side of the Moon, with additional photography of hidden side areas scheduled as well.

-more-

4/26/67

The 860-pound Orbiter will be launched by an Atlas-Agena D vehicle from Cape Kennedy, Fla., on a flight to the vicinity of the Moon which will take about 89 hours. When successfully injected on its translunar trajectory, it will be designated Lunar Orbiter IV.

The broad, systematic survey of lunar surface features is designed to increase scientific knowledge of the nature and origin of the Moon and of the processes by which its surface was formed and modified. The survey will supply the basis for planning and selecting sites for detailed scientific study by later orbital and landing missions.

It is expected that more than 80 percent of the front face of the Moon will be photographed in sufficient resolution to show surface features as small as 200 feet across. The pictures will be about 10 times more detailed than the best Earth-based photographs made through telescopes. In addition, photographs of the Moon's polar regions at lesser resolution will complete coverage of the full front face.

Photography on the hidden side of the Moon will provide pictures of objects 400 feet and larger, and will fill out the coverage begun by Lunar Orbiters I, II, and III. It is planned to cover more than 90 percent of the hidden side.

Lunar Orbiter D's photographic survey will be accomplished from a relatively high, nearly polar orbit around the Moon. The low point (perilune) of the intended orbit will be about 1,650 miles and the apolune (high point) about 3,800 miles. The spacecraft will require 12 hours to complete one circuit of the Moon at those altitudes.

The photographic flight plan is an ambitious one which assumes that all spacecraft systems, ground support systems, and the operations team will be able to operate at maximum efficiency. Once photography begins there will be picture-taking sequences on every orbit. It is planned that the pictures will be processed and read back to Earth receiving stations during the picture-taking phase although a complete final readout will be performed if required. The 12-hour orbital period permits this mode of operation.

The full photographic flight plan requires more than 200 camera-pointing maneuvers by Orbiter D where only 50 were required for the Lunar Orbiter III photographic flight plan.

In addition to its assignment of surveying the Moon photographically, Lunar Orbiter D, like its predecessor, will monitor proton radiation and meteoroids in the vicinity of the Moon. The detection equipment on the three Orbiter spacecraft flown thus far have counted a total of five meteoroid punctures.

The most notable radiation measurements were recorded by Lunar Orbiter I which clearly measured the effects of a series of solar flares which took place after its photography was complete.

Meteoroid and radiation measurements are used primarily for spacecraft performance analysis since the hermetically-sealed camera package potentially could suffer damage from meteoroid hit or the photographic film could fog from solar proton radiation.

Orbiter D, like its three predecessor, will add to and refine the definition of the Moon's gravitational field, although the higher orbital inclination and greater distance from the Moon will produce much smaller changes in orbit due to gravitational irregularities.

On the first day of the planned launch period, May 4, Orbiter's launch window is between 4:57 p.m. EDT and 8:10 p.m. EDT. On each succeeding day of the period, the window opens a few minutes earlier.

During its journey to the Moon, the spacecraft will be oriented to the Sun and the Southern hemisphere star Canopus, except when it is executing one or possibly two mid-course maneuvers.

A fairly large first midcourse maneuver will be required even assuming launch vehicle performance is as accurate as that achieved on the first three spacecraft of the series. This is because launch vehicle targeting was developed for a mission similar to Lunar Orbiter III.

At a point ranging about 2,350 miles from the Moon's surface, the liquid fuel retroengine will fire to slow the spacecraft so it will be captured by the Moon's gravitational field. As a satellite of the Moon, Lunar Orbiter will enter an initial elliptical orbit whose distance from the Moon will vary between 1,650 and 3,800 miles.

The high-altitude, high-inclination orbit (85°), markedly different from the flight paths of the first three spacecraft in the series, is necessary to permit the broad photographic survey of the Moon which is Lunar Orbiter D's principal assignment.

Photography is scheduled to begin May 11, regardless of the actual day of launch, and will be completed about May 28.

The relatively long orbital period -- about 12 hours -- and the fact that the spacecraft will only rarely disappear behind the Moon on its elliptical flight path, make possible to read back Lunar Orbiter D photographs on each orbit as they are taken and processed.

NASA will distribute lunar site photographs to members of the scientific community for interpretive studies. The U.S. Geological Survey will employ Lunar Orbiter photographs as basic material in its efforts to derive a more detailed understanding of the physical processes which played a part in the formation of the lunar surface as it exists today.

The Lunar Orbiter program is directed by NASA's Office of Space Science and Applications. The project is managed by the agency's Langley Research Center, Hampton, Va. The spacecraft are built and operated by the Boeing Co., Seattle, as prime contractor. Eastman Kodak Co., Rochester, N.Y., (camera system) and Radio Corporation of America, Camden, N.J., (power and communication systems) are the principal subcontractors to Boeing.

NASA's Lewis Research Center, Cleveland, is responsible for the launch vehicle and the Kennedy Space Center, Fla., will supervise the launch operation. Prime vehicle contractors are General Dynamics, Convair Division, San Diego, for the Atlas and Lockheed Missiles and Space Co., Sunnyvale, Cal., for the Agena.

Tracking and communications for the Lunar Orbiter program are the responsibility of the NASA Deep Space Network (DSN), operated by the Jet Propulsion Laboratory, Pasadena, Cal. DSN stations, located at Goldstone, Cal.; Madrid, Spain; and Woomera, Australia, will participate in the mission.

Photographic data gathered by Lunar Orbiter's fourth mission will flow from each DSN station to the Army Map Service, Washington, D.C., for reassembly and duplication. Some material will be reassembled and printed at NASA's Space Flight Operations Facility and at the Langley Research Center to support the selection of scientific sites under consideration as photographic targets for the fifth Orbiter mission.

(END OF GENERAL RELEASE; BACKGROUND INFORMATION FOLLOWS)

LUNAR ORBITER PROJECT

The Lunar Orbiter program was announced by NASA in August, 1963, as one of three major projects for unmanned exploration of the Moon in advance of Project Apollo.

In the following two years, three Ranger spacecraft, carrying television cameras, returned a total of 17,259 close-up photographs of the lunar surface enroute to crash landing and destruction on the Moon.

Surveyor I, launched May 30, 1966, achieved a successful soft-landing on the Moon's surface. It measured important surface properties -- for example, how much weight the lunar crust will support -- and transmitted 11,150 close-ups of the Moon's surface from its position in the Sea of Storms.

On Aug. 10, 1966, Lunar Orbiter I was launched and during the succeeding days, demonstrated its remarkable versatility as a flying photographic laboratory. Final tallies show that it photographed about two million square miles of lunar surface, including 16,000 square miles over prime target sites in the Apollo zone of interest on the front face of the Moon. It provided the first detailed scientific knowledge of the lunar gravitational field and topographic and geological information of direct benefit to the Apollo program and to scientific knowledge of the Moon.

On Oct. 29, after making 527 revolutions in 77 days of orbiting the Moon, Lunar Orbiter I was ordered to fire its velocity control engine for 97 seconds. At 9:30 a.m., EDT, it impacted the hidden side of the Moon. This was done to eliminate any possibility that Orbiter I could interfere with the Orbiter II mission by inadvertently turning on its radio transmitter.

Lunar Orbiter II, launched Nov. 6, 1966, flew an even more successful photographic mission, providing wide angle and telephoto coverage of more than 1.5 million square miles of the Moon's surface, not covered by Orbiter I, including 15,000 square miles of primary site photography in the Apollo zone.

By April 20, 1967, Lunar Orbiter II had completed more than 1,050 orbits, and is continuing to add to the scientific understanding of the lunar gravitational field through careful tracking. Lunar Orbiter III, launched Feb. 4, 1967, flew a mission designed to confirm earlier photography by Orbiters I and II.

Orbiters I, II and III have provided 35,000 square miles of primary site photography, 600,000 square miles of secondary site photography on the front side, and 3.6 million square miles of far side coverage.

By April 20, Lunar Orbiter III had completed more than 496 orbits of the Moon. It is providing a valuable function as a tracking target for stations of the Manned Space Flight Network, and continues as a source of information on micro-meteoroids, radiation, and selenodesy.

NASA's Office of Manned Space Flight has said the photographs obtained by the first three Lunar Orbiter spacecraft have made it possible to select eight areas containing locations potentially suitable for a manned landing by the Apollo Lunar Module. Further analysis of the site photography is continuing.

Lunar Orbiter and Surveyor data are being used together to gain a detailed understanding of selected areas of the lunar surface in order to make a safe manned landing possible.

-more-

ORBITER SPACECRAFT CONFIGURATION

The Lunar Orbiter spacecraft is a flying photographic laboratory, equipped with the necessary controls to position the camera correctly over the site to be viewed, and the means to extract the information contained in each photograph and send it back to Earth.

In flight configuration Lunar Orbiter is a truncated cone from whose base project four solar cell panels. It carries two antennas on rods extended from opposite sides of the spacecraft, and is covered with an aluminized mylar reflective thermal blanket.

Lunar Orbiter D weighs 860 pounds, and when folded for launch measures five feet in diameter by five and one-half feet tall. During launch the solar panels are folded against the base of the spacecraft and the antennas are held against the sides of the structure. A nose shroud only five feet, five inches in diameter encloses the entire spacecraft.

When the solar panels and antennas are deployed in space, the maximum span becomes $18\frac{1}{2}$ feet across the antenna booms and 12 feet, 2 inches across the solar panels.

The primary structure consists of the main equipment mounting deck and an upper section supported by trusses and an arch.

In the upper section are located the velocity control engine with its tankage for oxidizer, fuel and pressurization, and the attitude control thrusters. The nozzle of the engine extends through an upper heat shield.

The lower section houses the camera, communications and electrical system equipment, the inertial reference unit, the Sun sensor, and the Canopus star tracker.

Camera System

The technological ability to compress a complete photographic laboratory within an egg-shaped pressure shell with all parts weighing no more than 150 pounds makes the Lunar Orbiter mission possible. The package itself includes two cameras -- one for wide angle and the other for telephoto photography. The cameras view the Moon through a protective window of quartz, which in turn is protected by a mechanical flap in the thermal blanket which covers most of the spacecraft. The flap, or camera thermal door, is opened and closed by command at the beginning and end of every photographic pass over a section of lunar surface.

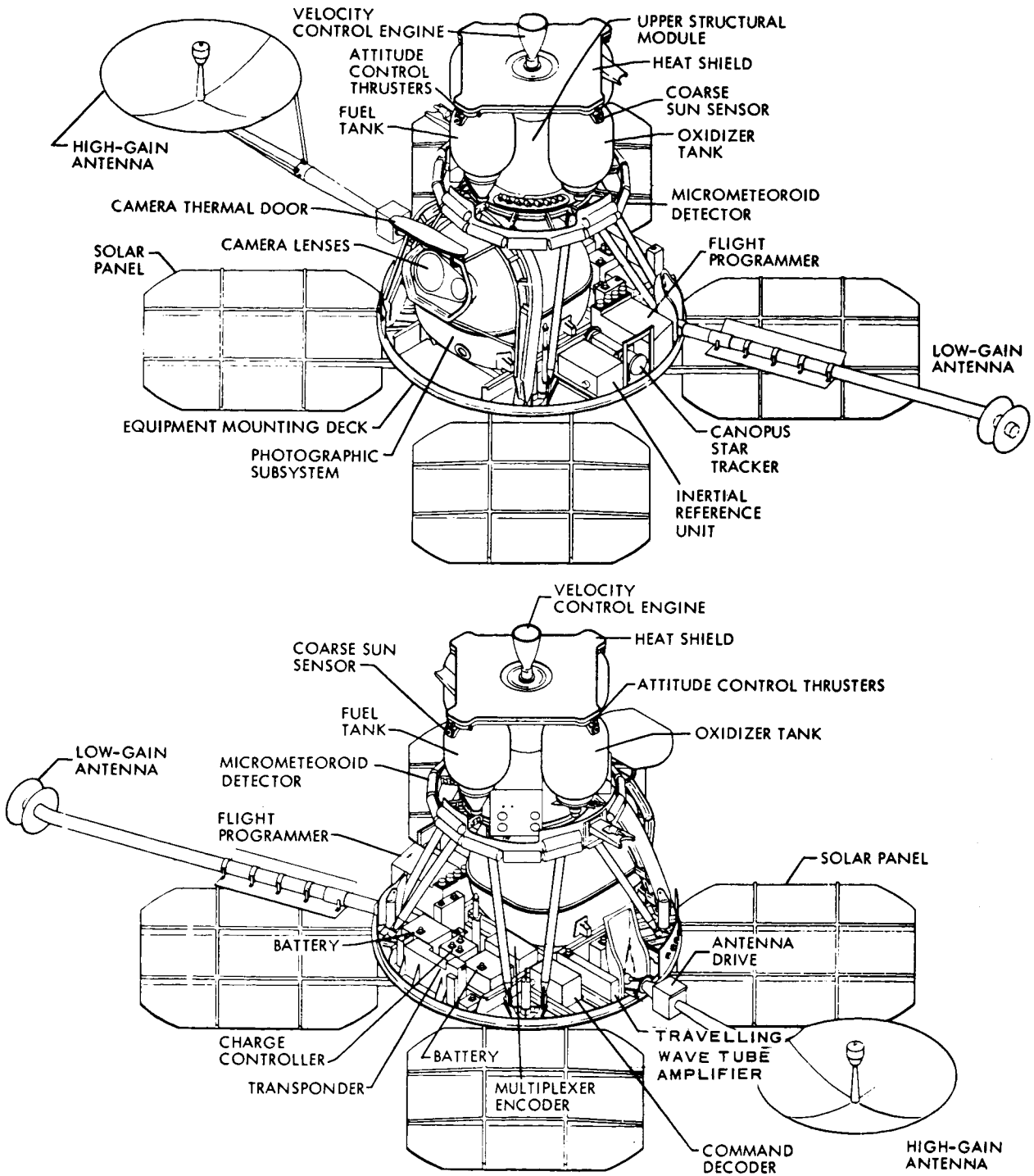

LUNAR ORBITER SPACECRAFT

The wide angle lens is an 80-mm Xenotar, manufactured by the West German firm of Schneider-Kreuznach. It is fitted with a fixed aperture stop of $f/5.6$ and a between-lens shutter to provide exposure speed selections of $1/25$, $1/50$ and $1/100$ second.

The telephoto lens is a 24-inch $f/5.6$ Paxoramic specially designed and built by Pacific Optical Company. The lens weighs less than 16 pounds and operates through a focal plane shutter adjustable on ground command to the same speed selections as the 80-mm lens.

Relatively low shutter speeds are required by the exposure index of the film, which is Kodak Special High Definition Aerial Film, Type SO-243. Although its aerial exposure index of 1.6 is slow in comparison with other films, it has extremely fine grain and exceptionally high resolving power. It is relatively immune to fogging at the levels of radiation normally measured in space.

Lunar Orbiter will carry a 260 foot roll of 70-mm SO-243 unperforated film, sufficient for at least 212 dual exposure frames. The supply spool is shielded against ionizing radiation from solar flares.

Along one edge of the film is a band of pre-exposed data, primarily resolving power charts and densitometric gray scales, which will be read out along with the lunar images captured by the spacecraft.

The gray scales are very important because they contain the key to correct interpretation of the Lunar Orbiter's photographs. Specifically, they provide the photometric calibration which will make it possible to estimate slopes on the Moon's surface by measuring film densities.

Photo Taking Process

Light gathered by the 24-inch lens is turned through a right angle by a mirror before it reaches the film, while the wide angle lens passes light directly to the film. Because of the camera's mechanical design, the two simultaneous images are not placed side by side on the film, but are interspersed with other exposures.

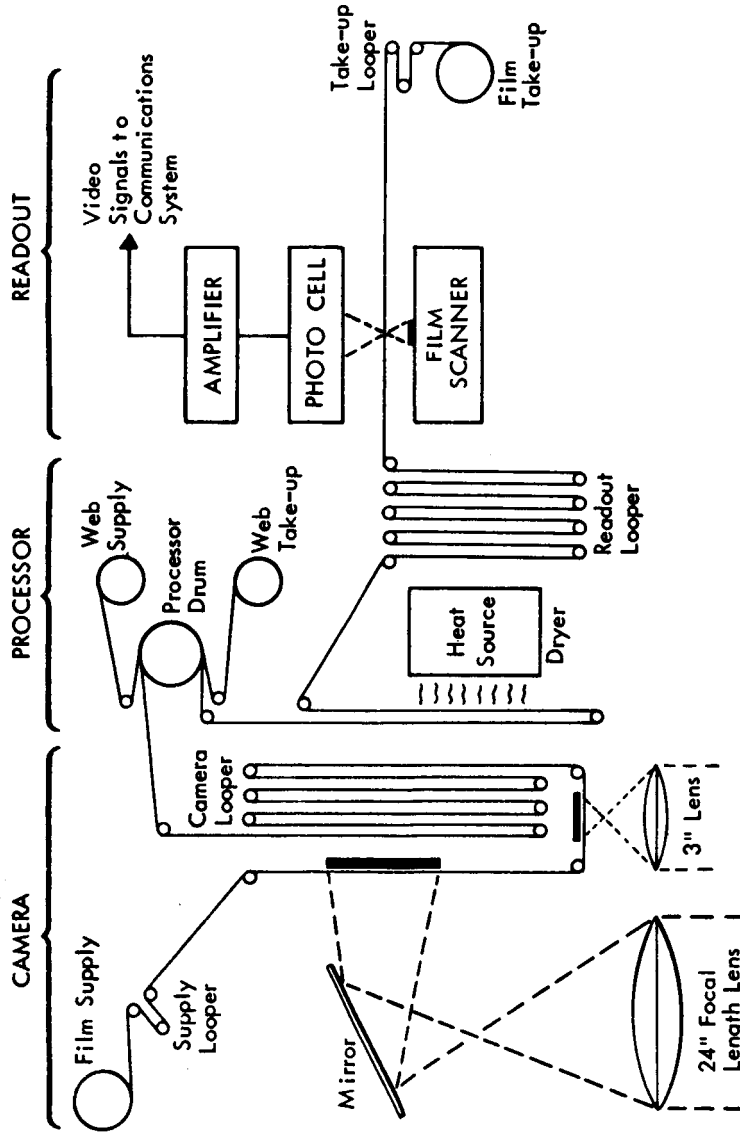

PHOTOGRAPHIC SUBSYSTEM

The image motion compensation device used on previous Lunar Orbiter missions will not be required because of the much higher altitudes from which Orbiter D pictures will be taken. The velocity over height (V/H) sensor remains part of the camera system but it will not be activated during the mission.

After exposure, the film moves forward to a storage or buffer area between the camera and processor. The buffer region or looper is provided to take up the slack between the camera and the processor. The looper is a system of pulley blocks which can be separated to store exposed film without slack. The looper can hold as many as 20 frames.

Photo Processing System

Next phase of the Lunar Orbiter's photographic system is a processor, in which the exposed film is chemically developed by the Eastman Kodak "Bimat" process.

The Bimat method uses a processing film or web whose gelatin layer has been soaked in a single developer-fixer solution of photographic chemicals. The film is slightly damp to the touch but little free liquid can be squeezed from it.

When the exposed film passes onto the processor drum and is mechanically pressed against the Bimat web, the chemical processes of negative development begin. Silver halide is reduced to silver in a few minutes, and undeveloped silver ions pass into the Bimat web material by a diffusion-transfer process. The Bimat web thereby acquires a positive image of the exposed view.

After processing is complete, the two films are separated and the used web material is reeled onto a take-up spool. No use is made of the positive images on the web.

The negative film, fully processed, passes between two chemically treated pads which remove much of its moisture, and is then fully dried by a small electric heater. When dry, the negative film is stored on a take-up reel until the electronic readout process is to begin.

Photo Readout Process

Readout is one of the most exacting tasks the Lunar Orbiter photographic system is required to perform.

There is no proved way of storing information which can compare in compactness with an image composed of silver grains in a gelatin emulsion on photographic film.

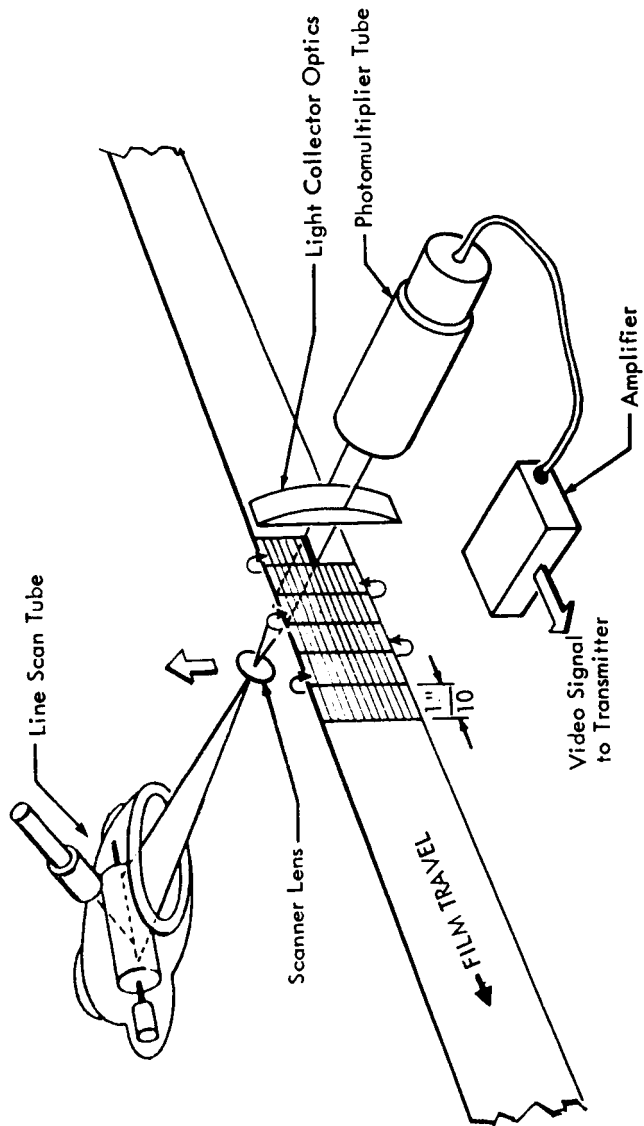

FILM SCANNER

The read-out method used by Orbiter must capture as much as possible of the film's densely-packed information and change it into a stream of electronic signals which can be transmitted to Earth.

A film scanner, in which a flying spot of light and suitable optical elements are linked with a photomultiplier, is the heart of the read-out equipment.

Light source for the flying spot is a Line Scan Tube developed by CBS Laboratories for film scanning applications. The tube contains an electron beam generator and a revolving drum whose surface is coated with a phosphorescent chemical.

As the electron beam moves across the surface of the phosphor, a thin spot of light is produced. The drum must be rotated to avoid burning at the electron intensities used.

The light generated by the tube is focused on the film through a scanning lens to a spot diameter of only five microns (a micron is one-thousandth of a millimeter or about 0.000039 of an inch).

The scanning lens moves the spot of light in a regular pattern across a small segment of the developed film, covering the 2.4-inch width of the image on the negative with 17,000 horizontal scans of the beam, each one-tenth of an inch long. A complete scan across the film takes 23 seconds, and when it is ended, the film advances one-tenth of an inch and the scanning lens travels over the next segment in the opposite direction.

By the process used, the Lunar Orbiter will require 40 minutes to scan the 11.6 inches of film which correspond to a single exposure by the two lenses.

As the spot of light passes through the image on the negative, it is modulated by the density of the image, that is, the denser portions transmit less light than sections of lower density.

After passing through the film, the light is sensed by a photomultiplier tube which generates an electronic signal proportional to the intensity of the transmitted light. The signal is amplified, timing and synchronization pulses are added, and the result is fed into the communications link as the Lunar Orbiter's composite video signal for transmission to Earth.

The flow of film through the Bimat processor cannot be reversed once started because the dry film would stick to the Bimat.

On previous missions, Lunar Orbiter employed a priority readout technique to return to Earth a portion of the photographs taken while the flight was in progress and a final readout to obtain complete photographic data.

The mission plan and orbit design for Lunar Orbiter D allow a different procedure, because there will be sufficient time to process and read back the pictures between photo-taking periods. The operating team thus expects to remain practically current with picture readout as the mission progresses.

The Lunar Orbiter D retains its ability to perform a complete readout after the photographic portion of the mission if required. At the conclusion of film processing, the Bimat web is cut so that the finished negative can be pulled backward through the processor and returned to the original film supply reel. After the Bimat web is cut, the spacecraft is no longer able to make photographs.

Should there be a requirement for additional readout, it would occur in reverse order from that in which the photographs were taken because of the inherent design of the photographic system. There is provision for repeated readout if required.

Electrical Power System

Lunar Orbiter carries a conventional solar panel-storage battery power system, with provisions for voltage regulation and charge control.

Primary source of power is an array of four solar panels, each slightly more than 13 square feet in area. There are 10,856 solar cells on the spacecraft panels--2,714 per panel. Each is an N-on-P silicon solar cell, 0.8-in. square, protected by a blue reflecting filter.

In full sunlight, the Lunar Orbiter solar panels produce about 375 watts of power. Total weight of the array, including the stowage and deployment mechanisms, is 70 pounds.

Energy produced by the solar panels is stored for use while the Lunar Orbiter is in shadow in a 20-cell nickel-cadmium battery rated at 12 ampere hours. The battery consists of two identical 10-cell modules; overall weight is 30 pounds.

Orbiter's electrical system voltage can vary from 22 volts when the batteries are supplying the load to a peak of 31 volts when the solar panels are operating.

The spacecraft power system includes a charge controller to regulate the amount of current to the battery while it is being recharged, and a shunt regulator to keep the solar array output from exceeding a safe maximum voltage.

During the first few months of its mission, Lunar Orbiter D will operate in full sunlight on nearly every orbit, and its charge controller has been changed to provide a lower charge rate than previous spacecraft of the series.

-more-

Attitude Control System

During the course of its mission, Lunar Orbiter D will be called upon to perform accurately a larger number of attitude changes than any previous spacecraft in the series. The current record is held by Lunar Orbiter I, which acted correctly on 4,446 commands and performed 347 separate attitude maneuvers.

The nature of the broad photographic survey mission assigned to Orbiter D will require a camera pointing maneuver each time a picture is to be taken. On previous missions, multiple photographs were made with a single pointing maneuver.

-more-

Orbiter's attitude control subsystem has been designed to accomplish these spacecraft events precisely and repeatedly, while retaining enough flexibility to respond to changes ordered by ground command.

Principal elements of the attitude system are the programmer, inertial reference unit, Sun sensors, Canopus tracker, an electronic control and switching assembly, and a set of reaction control thrusters.

The programmer is a low-speed digital data processing machine with a memory capacity large enough to provide 16 hours of control over a photographic mission from stored commands. It contains redundant clocks for timing mission events, and is designed to operate primarily in the stored program mode to accomplish the major mission objectives.

The programmer executes a stored program by bringing commands sequentially from its memory, completing them, and continuing to measure time until the next scheduled event. It is intended that the programmer memory will be periodically brought up to date by ground control, but the device can be operated in a real-time command mode if required.

In view of the many precise maneuvers which Lunar Orbiter must perform, the inertial reference unit is a particularly important element in the attitude control system. It has five main functions:

During an attitude maneuver, it reports the rate at which the spacecraft's attitude is changing, so that the flight programmer can send correct instructions to the reaction control jets which position the vehicle.

When photographs are being made or when the velocity control engine is in use, the inertial reference unit measures attitude errors so that the attitude control system can be directed to maintain the attitude required.

At times when the velocity control engine is firing, an accelerometer in the inertial reference unit furnishes a measurement which permits the programmer to cut off the engine at the proper instant.

While Lunar Orbiter is in cruise or coasting flight, the inertial reference unit senses small oscillations which can be expected to occur and provides signals to the attitude control jets for corrective action when needed.

In lunar orbit, the inertial reference unit furnishes a memory of the positions of the Sun or Canopus whenever the spacecraft is in a position from which its sensors cannot see either one or both of the basic celestial reference bodies.

The inertial reference unit is contained in a package 7 by 10 by 7 inches, and weighs about 13 pounds. In its beryllium main frame are mounted three single-degree-of-freedom, floated, rate-integrating gyroscopes and one pulsed integrating pendulum-type accelerometer. The remaining space in the container is filled with the six electronic modules required to operate the unit and relay its measurements to the Lunar Orbiter programmer. Its power requirements are low, never exceeding 30 watts at any point in the mission.

Twelve Sun sensors are carried on Lunar Orbiter to provide the celestial references needed for attitude control in pitch and yaw. Four are coarse sensors, mounted under the corners of the heat shield between the propellant tanks and the velocity control engine. A combination of eight coarse and fine Sun sensors views through the equipment mounting deck which forms the bottom surface of the spacecraft.

All Sun sensors measure the angle of spacecraft deviation from a direct line to the Sun and generate an electronic signal in proportion to the deviation. The signal can then be used by the attitude control system to adjust the attitude of the spacecraft.

The star tracker or Canopus sensor furnishes the celestial reference for the spacecraft's roll axis. Like the Sun sensors, it measures any angle of deviation of the Lunar Orbiter from a direct line to Canopus, and provides the necessary signal to begin a corrective maneuver when needed.

The star tracker is designed to produce a series of recognition signals from which a star map can be constructed by ground controllers. The map permits a positive determination that the tracker has locked onto Canopus rather than some other star within its field of view.

In flight, the Canopus tracker is used for the first time after the Lunar Orbiter has passed through the Van Allen radiation belts -- some six hours after launch. It is located on the Lunar Orbiter's main equipment mounting deck, and looks outward through an opening in the thermal blanket.

All parts of the attitude control system are interlinked by a flight electronics control assembly. It contains the reaction jet valve drivers, signal summing amplifiers and limiters, Sun sensor amplifiers and limiters, signal generators, switching arrangements and other electronic circuitry required by the system.

Eight reaction control thrusters use nitrogen gas from a titanium sphere directly beneath the velocity control engine to generate the torques needed to move Lunar Orbiter in roll, pitch or yaw. Gas expelled through the thrusters is distributed through a pressure reducing valve and plumbing system according to commands issued by the programmer.

The unusually active maneuvering program dictated by the survey mission will require an increase of about 10 percent in the quantity and pressure of nitrogen carried in the storage bottle aboard the spacecraft. Lunar Orbiter D will carry 16 pounds of nitrogen (versus about 14.5 pounds on previous spacecraft) at a pressure slightly above 4,100 psi. Earlier tank pressures were about 3,500 psi. The system has been thoroughly checked and approved for operation at the higher pressures.

Most of the nitrogen is budgeted for use in attitude control changes, for which it is regulated down to a pressure of 19 psi. About four pounds are assigned to the velocity control system to be used in pushing fuel and oxidizer from storage tanks into the velocity control engine.

Velocity Control System

In the Orbiter D mission, at least two and possibly three changes in spacecraft velocity will be required after the launch vehicle has completed its work.

The first will be a relatively large midcourse correction, planned for about 20 to 30 hours after launch.

The first midcourse maneuver will require a velocity change of about 180 feet per second, even with launch accuracies as precise as those experienced on the first three Orbiter flights. That change in velocity will require an engine burn of about 40 seconds.

Sufficient fuel will be carried to permit a second midcourse correction if required.

The most critical velocity change will come after about 89 hours of flight, as the spacecraft nears the Moon.

There the velocity control engine must execute a precision firing maneuver to slow Orbiter enough to allow it to enter an orbit about the Moon.

To make the necessary changes and to provide a small margin of extra capability, the Lunar Orbiter carries a 100-pound thrust engine and sufficient fuel and oxidizer to make velocity adjustments totaling about 3,280 feet per second.

Lunar Orbiter's velocity control engine was developed for Project Apollo, where it will be used in the Service Module and Lunar Module for attitude control.

Nitrogen tetroxide is the oxidizer and Aerozine 50 the fuel. Aerozine 50 is a 50-50 blend of hydrazine and unsymmetrical dimethyl-hydrazine (UDMH).

Both fuel and oxidizer are storable and hypergolic; that is, when mixed together the two liquids burn without the need for auxiliary ignition. Lunar Orbiter's four tanks divide the fuel and oxidizer to minimize changes in the spacecraft's center of gravity as propellants are consumed. About 270 pounds of usable propellants will be carried in the spacecraft tanks.

The same source of gaseous nitrogen used for the attitude control thrusters provides a positive method to push the propellants from their tanks into the velocity control engine when required. Each tank has within it a teflon bladder which exerts a positive pressure against the liquid when nitrogen is admitted to the opposite face. The tanks are pressurized to about 200 pounds per square inch.

Tank pressurization will be commanded a short time before the first midcourse maneuver. When the maneuver is to begin, the attitude control system places the spacecraft in an attitude based on ground computations and the programmer transmits an opening signal to solenoid valves on the fuel and oxidizer lines. Thrusting begins when the fuel and oxidizer mix and burn in the engine's combustion chamber.

While thrusting, the accelerometer in the inertial reference unit constantly measures the change in velocity as it occurs, and when the desired increment is achieved, the solenoid valves are commanded to close and the engine stops firing.

The velocity control system is capable of as much as 710 seconds of operation and at least four engine operating cycles.

Communications System

The Lunar Orbiter communication system is an S-band system compatible with the existing NASA Deep Space Network and capable of operating in a variety of modes.

It enables the spacecraft to:

Receive, decode and verify commands sent to the spacecraft from Earth;

Transmit photographic data, information on the lunar environment gathered by the radiation and micrometeoroid detectors, as well as information on the performance of the spacecraft;

Operate in a high power mode when photographic information is being transmitted, and a low power mode at other times;

Provide by ground command the ability to choose the transmitting power mode and to turn the transmitter off and on.

The heart of the Lunar Orbiter's communication system is a transponder basically similar to the type flown on Mariner IV.

The transponder receives a transmitted command from Earth and passes it to a decoder where it is stored temporarily. The command is then re-transmitted to Earth through the transponder to verify that it has been correctly received. When verification is confirmed, an execute signal is sent from Earth causing the decoder to pass the command along to the programmer for immediate or later use as required. The command transmission rate is 20 bits per second.

In the tracking and ranging mode, the transmitting frequency of the transponder is locked to the frequency of the signal being received from Earth in a precise ratio. The signals can then be used to determine the radial velocity of the spacecraft to an accuracy of about one foot per second. When interrogated by the Deep Space Network ranging system, the transponder signal will measure the distance between the Earth and the spacecraft with an accuracy of about 100 feet.

A low power operating mode delivers spacecraft performance telemetry and data from the lunar environment experiments (radiation and meteoroids) to Earth at 50 bits per second. Telemetry is in digital form, and has been passed through a signal conditioner, a multiplexer encoder and a modulation selector before transmission.

A high power communication mode is used to transmit photographic data in analog form and brings into use the spacecraft's high gain antenna and a traveling wave tube amplifier. Performance and environmental telemetry will be mixed with the photographic information in the transmission.

During photographic data transmission, the spacecraft uses a 10-watt transmitter and a high gain antenna. At other times, a one-half watt transmitter and a low gain antenna are used to conserve battery power.

A low gain antenna is hinge-mounted at the end of an 82-inch boom. It is deployed in space after the heat shield is jettisoned. The hinge is spring loaded and fitted with a positive locking latch to keep the boom in deployed position. The radiation pattern of the low gain antenna is virtually omnidirectional.

By contrast, the high gain antenna which is used when pictures are transmitted is quite directional, having a 10-degree beam width. It is therefore equipped with a rotational mechanism so that it can be correctly pointed toward the Earth station receiving its transmissions.

The high gain antenna is a 36-inch parabolic dish of lightweight honeycomb construction. It is mounted on the end of a 52-inch boom and is deployed after heat shield jettison in the same way as the low gain antenna. The antenna dish and feed weigh only two and one-third pounds.

A motor driven gear box at the base of the high gain antenna boom allows the boom to be rotated in one degree steps to point the antenna accurately toward the Earth receiver.

Temperature Control System

Lunar Orbiters are equipped with a passive temperature control system to carry away heat generated by the energy used in operation and to limit the amount of heat absorbed when the spacecraft is in direct sunlight.

The high elliptical orbit planned for Lunar Orbiter D will expose the spacecraft to virtually constant sunlight for the first 30 days of its flight. During that period, it will enter shadow on only two brief occasions.

For that reason, special steps have been taken to allow that spacecraft to reject more solar heat than its predecessors.

All sides of the spacecraft are insulated, except the equipment mounting deck which forms the bottom of Lunar Orbiter.

The mounting deck forms a heat sink to dissipate heat generated by equipment inside the Orbiter. To do so it must be able to radiate heat much more readily than it absorbs solar energy.

For previous Orbiters, it proved sufficient to coat the equipment mounting deck with a special white reflective paint. Additional protection has been provided for Orbiter D by cementing to the painted surface 458 small mirrors, each one inch square. By reflecting sunlight falling on the deck, the mirrors will compensate for the added time the spacecraft will spend in full sunlight.

On Orbiter's upper surface, the heat shield on which the velocity control engine is mounted is insulated, and the entire surface of the spacecraft within those boundaries is covered with a multilayer thermal blanket composed of alternating layers of aluminized mylar and dacron cloth. The high reflective aluminized mylar will effectively prevent solar heat from reaching the interior of the spacecraft.

During flight from the Earth to the Moon, Lunar Orbiter's temperature inside the thermal blanket will vary between 40 and 75 degrees F. In lunar orbit, the spacecraft internal temperatures will range between 35 and 85 degrees F.

All external parts of the spacecraft are capable of withstanding full sunlight for an indefinite period.

LUNAR ORBITER TASKS

Lunar Orbiter D's primary objective is to make a broad, systematic photographic survey of lunar surface features to increase scientific knowledge of their nature, origin, and processes, and to serve as a basis for selecting sites for more detailed scientific study by subsequent orbital and landing missions.

From the survey, science will acquire a pictorial record of more than four fifths of the Moon's front face about 10 times more detailed than the best Earth-based telescope photography. In addition, the flight plan includes near-vertical photography at high latitudes near the polar regions to complete the front side coverage, photography around the Moon's western limb, and additional coverage of hidden side areas to fill out pictures made on the previous Lunar Orbiter missions.

The goals of increased scientific knowledge of the Moon were stated in 1963 by the President's Scientific Advisory Committee:

"...The central problems around which scientific interest in the Moon revolve concern its origin and history and its relationship to the Earth and the solar system. The Moon is a relatively unspoiled body, its surface not having been subject to wear and tear of erosion by an atmosphere and water. Hence a study of its surface may tell us its history, its age, whether it was formed when the solar system was formed, whether at some time it was separated from Earth or whether it was captured by Earth at some time in its history. Answers to these questions may profoundly affect our views of evolution of the solar system and its place, as well as man's, in the larger scheme of things..."

In pursuit of those goals, the Apollo, Ranger, Surveyor and Orbiter programs have been carried forward as an integrated effort to explore the Moon with manned and unmanned spacecraft.

The first three Lunar Orbiters had as their prime objective the location and confirmation of sites suitable for early manned Apollo and unmanned Surveyor landings.

In April, 1967, NASA announced selection of eight candidate Apollo landing sites which had been identified from Orbiter photography. With that phase of the program essentially complete, the fourth Orbiter mission has been designed to serve general scientific needs and to prepare the way for future orbital and landing missions.

Lunar Orbiter D will contribute to three additional areas of scientific inquiry through the following experiments:

- Selenodesy, the study of the gravitational field and shape of the Moon;
- Meteoroid measurements along the translunar trajectory and in orbit near the Moon;
- Radiation measurements in cislunar and near-lunar space.

Information obtained from the selenodesy experiment will increase knowledge of the Moon's gravitational field obtained through detailed tracking of Orbiters I, II and III. The high inclination orbit planned for Lunar Orbiter D will carry it through portions of the Moon's gravitational field hitherto untraversed, and should expand the knowledge previously accumulated.

Prior to the Lunar Orbiter program, detailed knowledge of the Moon's gravitational field did not exist. After three successful missions, it is now possible to predict orbital lifetimes accurately and to operate spacecraft with confidence in orbits closely approaching the surface of the Moon.

Meteoroid and radiation data are primarily gathered for spacecraft performance analysis but also are of considerable scientific interest.

Lunar Photography

Lunar photography is Orbiter's principal assignment, and the Orbiter D mission has been built around the requirement to obtain high quality photographs of large areas of the Moon's surface in detail far exceeding that visible through the best Earth-based telescopes.

From these photographs, scientists will be able to select promising locations for more detailed inspection by later orbiting or landing spacecraft. The pictures will also form the basis for a lunar surface map containing a hundredfold increase in detail over the best available maps constructed from telescope photography.

The Orbiter D flight has been planned to yield a maximum of scientific information about the lunar areas to be photographed. It will include regions close to the poles which have never been directly viewed by telescope or spacecraft. Because of the orientation of the Moon's axis to the plane of the ecliptic, however, there are areas at or near the poles upon which sunlight never falls, and pictures of those regions may not equal the quality of other Orbiter photographs.

NASA engineers expect to operate the Orbiter D camera in a single frame mode except on the first picture-taking orbit. In order to move exposed film into position for readout, 20 frames are scheduled on that orbit, four over each of five target positions, separated by about nine seconds between shutter operations.

On each succeeding orbit, five single frame exposures will be made as the spacecraft moves from south to north over the Moon's front face. A sixth single-frame hidden-side photograph will be taken on alternate orbits.

As on previous flights, Lunar Orbiter pictures will be taken shortly after sunrise on the Moon, with light falling on the lunar surface at a shallow angle to bring out the best detail. As the Moon turns beneath the orbit of the spacecraft, succeeding segments of the areas to be photographed come into view of the camera on each orbit.

It is desired to begin the photographic survey at 90° East, and to continue through 90° West or beyond if operating conditions permit. Should launch occur at the end of the window, it may be necessary to begin the east limb coverage at less than 90° to allow sufficient time to evaluate the orbit.

A typical photographic sequence on the front face of the Moon will take place on the ascending node of the orbit, that is, as the spacecraft is moving from South (bottom) to North (top) across the lunar surface.

A three-axis maneuver will position the camera for the first exposure and additional maneuvers will be required for the second, third, fourth and fifth. At the end of the sequence, another three-axis maneuver will return the spacecraft to its cruise position. The hidden-side pictures will require an additional three-axis maneuver.

Since the maneuver sequences will be required on every photographic orbit, the mission places a rigorous demand on the attitude control system and the nitrogen gas supply aboard the spacecraft.

During the remainder of each orbit, the spacecraft will process film and relay pictures to Deep Space Net stations.

Mission plans contemplate readout on a nearly current basis, although actual flight conditions may cause some revision. About 25 frames of photography will remain for readout after the last of the 212 scheduled frames is exposed.

Readout of a complete frame -- one wide angle and one telephoto picture -- takes about 43 minutes. For readout it is necessary to have the spacecraft's high gain antenna pointed at one of the Deep Space Net receiving stations.

Selection of the broad survey mission assigned to Lunar Orbiter D was made by the NASA Surveyor-Orbiter Utilization Committee, working on recommendations from various scientific groups and NASA and other government agencies.

Selenodesy

Major uncertainties about the detailed nature of the Moon's gravitational field were dispelled by the scientific contributions of Lunar Orbiters I, II and III, and as a result operations in lunar orbit can now be conducted with considerable confidence.

Although we now possess enough knowledge of the lunar gravitational field to operate spacecraft freely in lunar orbit, there is a requirement for much more detailed study and Lunar Orbiter D, like its predecessors, will be tracked with care in its high inclination, high altitude orbit.

The Moon, according to the best existing analysis, is relatively "smooth," that is, its gravitational field does not appear to possess large or unusual variations. It is sufficiently non-uniform to produce small changes in the track of any satellite around it, and these small changes, suitably evaluated by complex computer programs, permit scientists to deduce from tracking data further information about lunar gravity.

Selenodetic analysis of the tracking data of Lunar Orbiters I and II has yielded a description of the lunar gravity field which will be used in making operational lifetime predictions for managing the mission of Lunar Orbiter D. Post flight analysis of the tracking data of Lunar Orbiter D will, in a long range sense, contribute to future manned and unmanned missions near the Moon.

Principal investigator for the Lunar Orbiter selenodesy experiment is William H. Michael, Jr., Head of the Mission Analysis Section, NASA Langley Research Center. Co-investigators are Robert H. Tolson, Langley; and Jack Lorell and Warren Martin of NASA's Jet Propulsion Laboratory.

Meteoroid Measurements

Orbiter D will carry 20 pressurized-cell detectors to obtain more direct information on the presence of meteoroids in the near-lunar environment.

As the photographic system is enclosed in a thin-walled aluminum container which provides a controlled pressure and humidity environment for the operation of the camera system, a puncture of this container wall by meteoroids could result in performance degradation of this system. If such a degradation occurs, the meteoroid data could give clues to its cause.

Thus, the meteoroid information will guide designers of future spacecraft by determining what hazard, if any, should be expected from meteoroids -- small particles of solid matter which move at very high speeds in space.

The 20 pressurized cell detectors mounted on Lunar Orbiter were made in the instrument shops of the Langley Research Center. Each is shaped like a half cylinder seven and one-half inches long.

The puncture-sensitive skin of each half cylinder is beryllium copper 1/1,000-inch thick. The detectors are mounted girdle-wise outside the Lunar Orbiter's thermal blanket, on brackets attached to the fuel tank deck of the spacecraft.

A total surface area of three square feet is provided by the 20 cells.

At launch, each cell is pressurized with helium gas. If a meteoroid punctures the thin beryllium copper skin the helium leaks away, and a sensitive metal diaphragm inside the half cylinder detects the loss of pressure and closes a switch to indicate that a puncture has occurred. Periodic sampling of the pressure cell switches by telemetry indicates whether any have been punctured.

Experimenter for the meteoroid measurements is Charles A. Gurtler, Head of the Sensor Development Section of the Langley Research Center's Flight Instrumentation Division. Project Engineer is Gary W. Grew of Langley.

Radiation Measurements

The photographic film aboard Lunar Orbiter is sensitive to radiation exposure and the supply reel is shielded to reduce the possibility of damage.

To report the actual amounts of radiation to which the spacecraft may be subjected on its way to the Moon and during lunar orbits, two scintillation counters are included among its instruments. One measures the dosage at the film supply reel and the other the dosage at the storage looper.

Although their primary job is to report radiation intensities which might be hazardous to the film, they will supply additional information about the radiation found by Lunar Orbiter along its flight path.

Experimenter for the Radiation Measurements is Dr. Trutz Foelsche, Staff Scientist of the Langley Research Center's Space Mechanics Division.

ATLAS-AGENA D LAUNCH VEHICLE

An Atlas Agena D launch vehicle will boost Lunar Orbiter D from Launch Complex 13 at Cape Kennedy to an approximate 115-mile-high parking orbit before injecting the spacecraft on its lunar trajectory.

The upper-stage Agena must start the spacecraft on its way to the Moon through a narrow translunar injection point some 118 miles above the Earth's surface. Injection velocity is 24,400 miles per hour with an allowable error of less than 54 miles per hour.

Because Orbiter D's planned polar orbit will require greater use of the spacecraft's midcourse motor, the Atlas-Agena launch vehicle must be very precise in placing the Orbiter spacecraft on its initial lunar trajectory.

The accuracy required of the launch vehicle is such that if uncorrected, Lunar Orbiter will pass within 12,000 miles of the Moon after traveling some 250,000 miles.

The Orbiter shroud is made of magnesium with a beryllium nose cap. Its over-the-nose design is similar to that developed for the successful Mariner IV flight to Mars.

The spacecraft adapter is the mounting structure that supports the spacecraft, the shroud and a sealing diaphragm, and provides a transition from the Orbiter to the Agena. It includes four spring-loaded plungers to push the spacecraft from Agena at separation and a V-band release mechanism with associated pyrotechnic devices. This structure is made of magnesium.

Atlas Agena D Statistics

Total Height on Pad	105 feet
Total Weight on Pad	279,000 pounds

	<u>Atlas</u>	<u>Agena D</u>
Height	68 feet	23 feet
Diameter	10 feet	5 feet
Weight (at liftoff)	261,000 lbs.	15,600 lbs.

	<u>Atlas</u>	<u>Agena D</u>
Propellants	RP-1 (11,530 gallons) LOX (18,530 gallons)	unsymmetrical di- methyl hydrazine UDMH (585 gallons) and inhibited red fuming nitric acid IRFNA (745 gallons)
Propulsion	2 Rocketdyne boosters, 1 sustainer and 2 verniers	Bell Aerosystems Engine
Guidance	G.E. Mod III	Lockheed inertial reference package
Prime Contractors	General Dynamics/ Convair, San Diego, Calif.	Lockheed Missiles & Space Co., Sunny- vale, Calif.

DEEP SPACE NETWORK

The NASA Deep Space Network (DSN) consists of a number of permanent space communications stations strategically placed around the world; a spacecraft monitoring station at Cape Kennedy, and the Space Flight Operations Facility (SFOF) in Pasadena, Cal.

Permanent stations include four sites at Goldstone, in the Mojave Desert, Cal.; two sites in Australia, at Woomera and Tidbinbilla near Canberra; Robledo and Cebreros sites, near Madrid, Spain; and Johannesburg, South Africa. All are equipped with 85-foot-diameter antennas except the site at Goldstone which has one 210-foot-diameter antenna.

The DSN is under the technical direction of the Jet Propulsion Laboratory for NASA's Office of Tracking and Data Acquisition. Its mission is to track, communicate, receive telemetry from and send commands to unmanned lunar and planetary spacecraft from the time they are injected into orbit until they complete their missions.

The DSN uses a Ground Communications System for operational control and data transmission between these stations. The Ground Communications System is part of a larger net (NASCOM) which links all of the NASA stations around the world. This net is under the technical direction of the Goddard Space Flight Center, Greenbelt, Md.

The Goldstone DSN stations are operated by JPL with the assistance of the Bendix Field Engineering Corp. JPL also operates the Robledo and Cebreros sites under an agreement with the Spanish government. Technical support is provided by Bendix.

The Woomera and Tidbinbilla stations are operated by the Australian Department of Supply. The Johannesburg station is operated by the South African government through the Council of Scientific and Industrial Research and the National Institute for Telecommunications Research.

Stations of the network receive radio signals from the spacecraft, amplify them, process them to separate the data from the carrier wave and transmit required portions of the data to the SFOF in Pasadena via high-speed data lines, radio links, and teletype. The stations are also linked with the SFOF by voice lines. All incoming data are recorded on magnetic tape.

The DSN stations assigned to the Lunar Orbiter project are the Echo station at Goldstone, Woomera, and Madrid. Equipment has been installed at these stations to enable them to receive picture data from the Lunar Orbiter spacecraft. Since these three stations are located approximately 120 degrees apart around the world, at least one will always be able to communicate with the spacecraft as it travels toward the Moon.

The Space Flight Operations Center (SFOF) at JPL, the command center for the DSN stations, will be the primary mission control point. The overseas stations and Goldstone are linked to the SFOF by a communications network, allowing tracking and telemetry information to be received and displayed in real time. Key personnel for the Lunar Orbiter program will be stationed at SFOF during the spacecraft's flight. Commands will be generated at SFOF and transmitted to the DSN station for relay to the spacecraft.

Data Acquisition

The Lunar Orbiter spacecraft was designed for maximum compatibility with existing equipment installed at DSN stations. Additional equipment installed at the three Deep Space Network stations assigned to the Lunar Orbiter project includes three racks of telemetry and command equipment and four racks of equipment associated with the processing and recording of photographic information from the spacecraft.

Spacecraft tracking and ranging is accomplished by existing DSN equipment at the stations. Telemetry data, including spacecraft housekeeping information and data gathered by meteoroid and radiation sensors is routed to performance telemetry equipment and recorded on magnetic tape. The output from this equipment is fed directly to the SFOF via high speed data lines or teletype.

Video data are routed from the receiver at the DSN station to photographic ground reconstruction equipment. A video signal is generated on board the spacecraft as the scan beam passes back and forth across the photographic negative. The signal is transmitted to Earth where it is magnetically taped and displayed line by line on a kinescope.

The face of the kinescope is photographed by special 35mm cameras at the DSN stations, converting the video information back to photographic image. Two 35mm film records are made at each DSN station. Portions of this film are processed at the station so that picture quality may be judged and corrections made, if necessary, to the spacecraft camera or readout system to improve the quality of subsequent pictures.

Each of these 35mm framelets measures approximately 3/4-inch wide by 16-3/4 inches long, and represents a portion of the original film on board the spacecraft only 1/10-inch wide and 2.165 inches long. By carefully assembling a series of these framelets, scientists will be able to reconstruct a duplicate about seven times as large as the original negative stored on the spacecraft. This work will be accomplished at the U.S. Army Map Service, Washington, D.C.

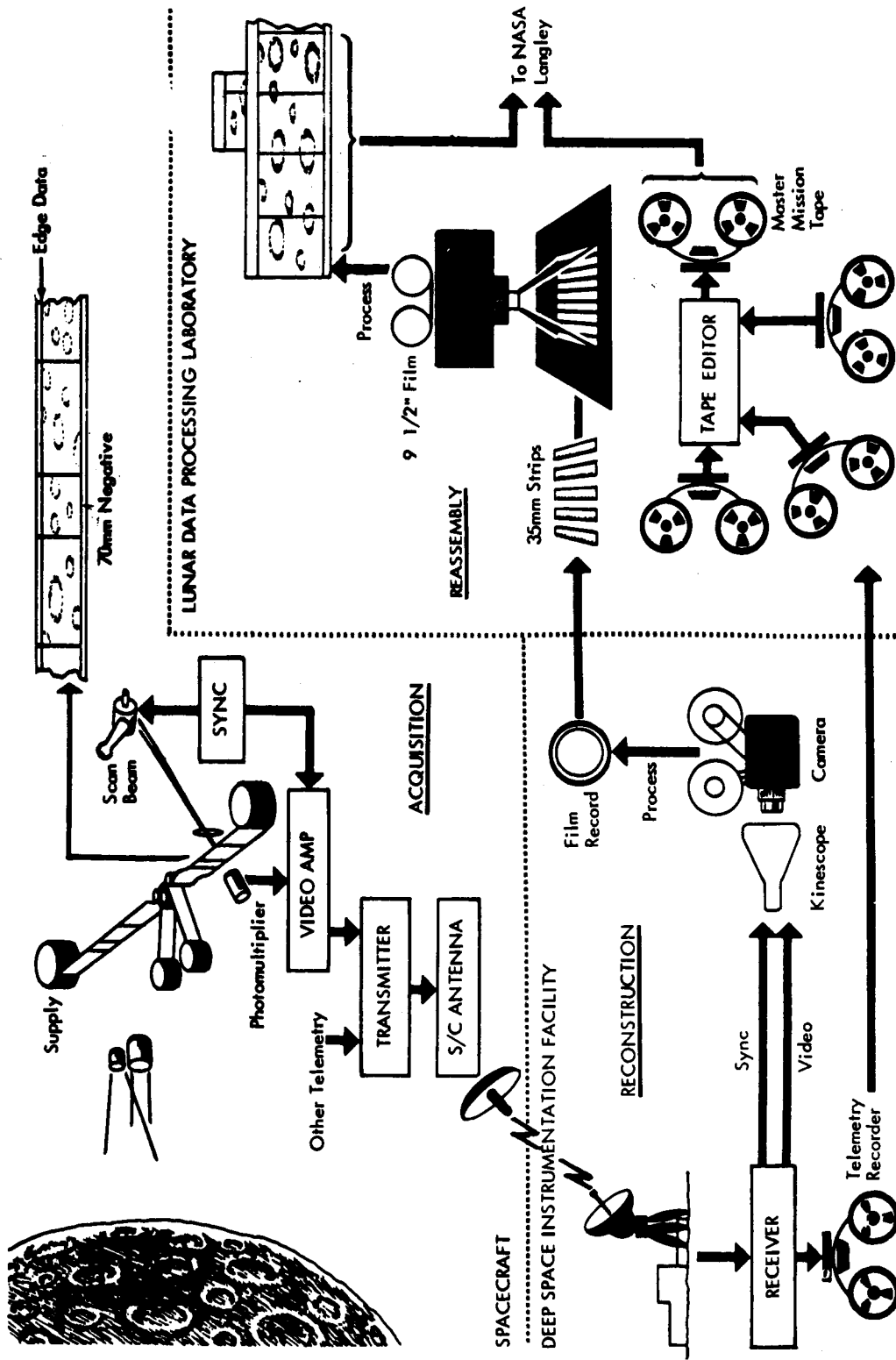

PHOTOGRAPHIC DATA ACQUISITION, RECONSTRUCTION, AND REASSEMBLY

Data Evaluation

Although eventual reassembly and final printing of Lunar Orbiter D photography will be done by the Army Map Service Laboratories, there will be preliminary reassembly in NASA facilities at Pasadena and the Langley Research Center to provide early material for screening by the Lunar Orbiter E site selection group.

Later and more detailed evaluations of the photographs will be made by individual lunar scientists, members of the U.S. Geological Survey, and representatives of several U.S. Government mapping agencies, as well as NASA scientists.

-more-

ATLAS-AGENA D/LUNAR ORBITER D MISSION

Approximate launch times* for the May period of a Lunar Orbiter D launch are:

<u>Day</u>	<u>Window Opens(EDT)</u>	<u>Window Closes(EDT)</u>
May 4	4:57 p.m.	8:10 p.m.
May 5	4:54 p.m.	8:22 p.m.
May 6	4:50 p.m.	8:39 p.m.
May 7	5:15 p.m.	9:06 p.m.

*Subject to additional tracking and range restrictions.

Countdown Events

<u>Event</u>	<u>Minus Time (Minutes)</u>
Start Count	395
Start UDMH Tanking	155
Finish UDMH Tanking	135
Start Removal of Gantry	130
Complete Removal of Gantry	100
Start IRFNA Tanking	90
Finish IRFNA Tanking	65
<u>Built-in Hold of 50 minutes</u>	60
(To meet launch window requirements)	
Start LOX Tanking	45
<u>Built-in Hold of 10 minutes</u>	7
(To meet launch window requirements)	
Secure LOX Tanking	2
Hold for Automatic Sequencer	18 seconds
Atlas engines to Full Thrust	2 seconds

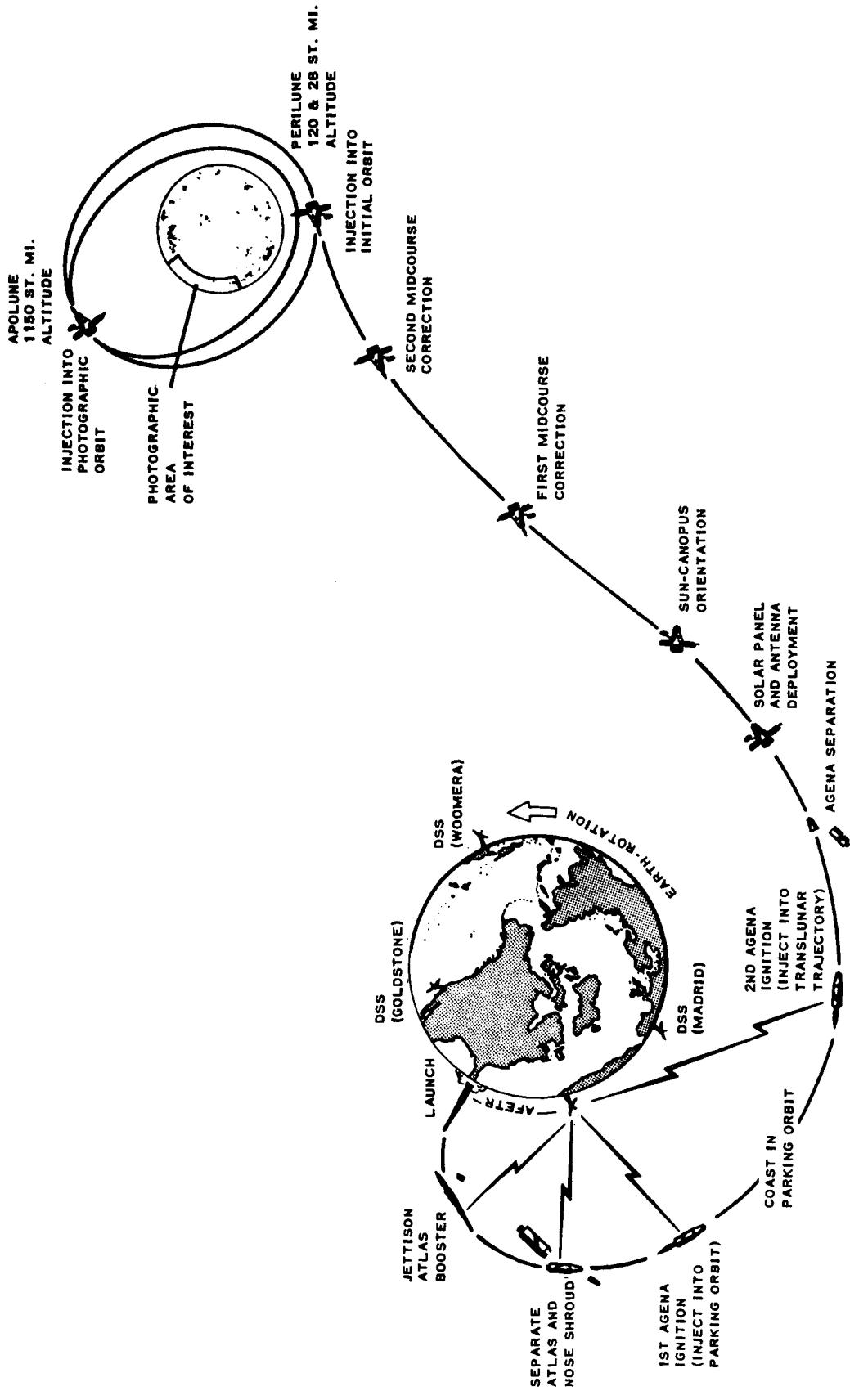

TYPICAL FLIGHT PROFILE

FLIGHT EVENTS SUMMARY

<u>Event</u>	<u>Plus Time (Seconds)</u>	<u>Velocity</u>	<u>Altitude</u>	<u>Miles Downrange</u>
Booster Engine Cutoff (BECO)	128	6,625	33	50
Jettison Booster Section	131	6,704	34	55
Sustainer Engine Cutoff (SECO)	289	12,650	93	400
Vernier Engine Cutoff (VECO)	309	12,630	100	462
Jettison Shroud	311	12,628	100	469
Atlas-Agena Separation	313	12,624	101	475
Start Agena First Burn	366	12,560	112	647
End Agena First Burn	519	17,445	115	1,214
Start Agena Second Burn	2,032	17,448	114	7,978
End Agena Second Burn	2,120	24,470	118	8,440

-more-

Launch Vehicle Flight

The vehicle's time in parking orbit will vary from 926 seconds to as much as 1,870 before the sequence is begun to ignite Agena's engine for the second time. Lunar Orbiter must be started on its 90-hour coast to the Moon at a velocity of 24,400 mph plus or minus a margin for error of only 54 mph. The exact velocity-to-be-gained will be dependent on previous flight events but the figure should be about 7,000 mph requiring some 88 seconds of engine operation.

Agena must inject Lunar Orbiter toward the Moon at a point in space which remains relatively fixed. However, the Earth turns under this stationary gateway to the Moon and the actual injection time varies with the day and hour of the launch.

Launch vehicle performance varies somewhat, thus the times of actual flight events are determined during the flight when the desired speed and altitude are required.

At the correct point on the ascent trajectory, the radio guidance system starts the Agena primary timer which controls all Agena events except engine shutdown. Both parking orbit and injection conditions are highly influenced by the point on the ascent trajectory at which the Agena primary timer is started.

Agena's velocity meter controls the duration of engine burn. It is preset with the velocity-to-be-gained in each case and, when that velocity is gained, the engine is shut down. That is, should Agena's 16,000-pound-thrust engine burn a little hotter, the time of engine operation will be shorter than that given as nominal but the end effect of the desired vehicle velocity will be the same.

After Agena's engine shuts down for the final time, the spacecraft release assembly bolt squib is fired to release the V-band clamp. Four spring-loaded separation mechanisms push the spacecraft away from the Agena at slightly less than one mile per hour and the Lunar Orbiter spacecraft will be on its translunar trajectory.

Three seconds after spacecraft separation, Agena begins a yaw maneuver which will turn it around 180° in space. Then 10 minutes after separation, a signal from the primary timer fires Agena's retrograde rocket for about 16 seconds. This 137-pound thrust retrograde rocket slows Agena 30 mph to minimize the possibility that the vehicle could interfere with Orbiter or hit the Moon. With its launch job done, Agena will go into a high eccentric Earth orbit.

First Spacecraft Events

Thirty seconds after the Lunar Orbiter leaves Agena, a sequence of spacecraft events is commanded by the programmer, starting with solar panel deployment. Next the two antennas are released and locked in their cruise positions.

The spacecraft is then commanded to begin Sun acquisition, and the attitude control system provides the necessary torque to position Lunar Orbiter correctly. Sun acquisition should be complete about one hour and 15 minutes after lift-off.

Some six and one-half hours into the flight, and after Lunar Orbiter has passed beyond the Van Allen radiation belt, the Canopus sensor will be turned on, and the spacecraft will be commanded to begin Canopus acquisition. The Canopus tracker will view a circular band of the heavens while the spacecraft is making a complete roll, and the resulting "star map" telemetered to Earth will confirm the location of Canopus. The spacecraft will then be commanded to roll to the correct Canopus location and lock on to the stellar reference point it will use throughout its journey.

First midcourse maneuver is scheduled about 20 to 30 hours after lift-off, although the precise time for executing it will be based on actual flight events, including launch accuracy and tracking results.

A correct sequence of events derived from ground computers will be stored in the spacecraft programmer and at the selected time, Orbiter's attitude control system will position the spacecraft precisely for the velocity control engine to apply the needed thrust. After thrusting, the attitude control system returns the spacecraft to its initial orientation, reacquiring the Sun and Canopus as references.

Should a second midcourse correction prove necessary, it will be made about 70 hours after launch.

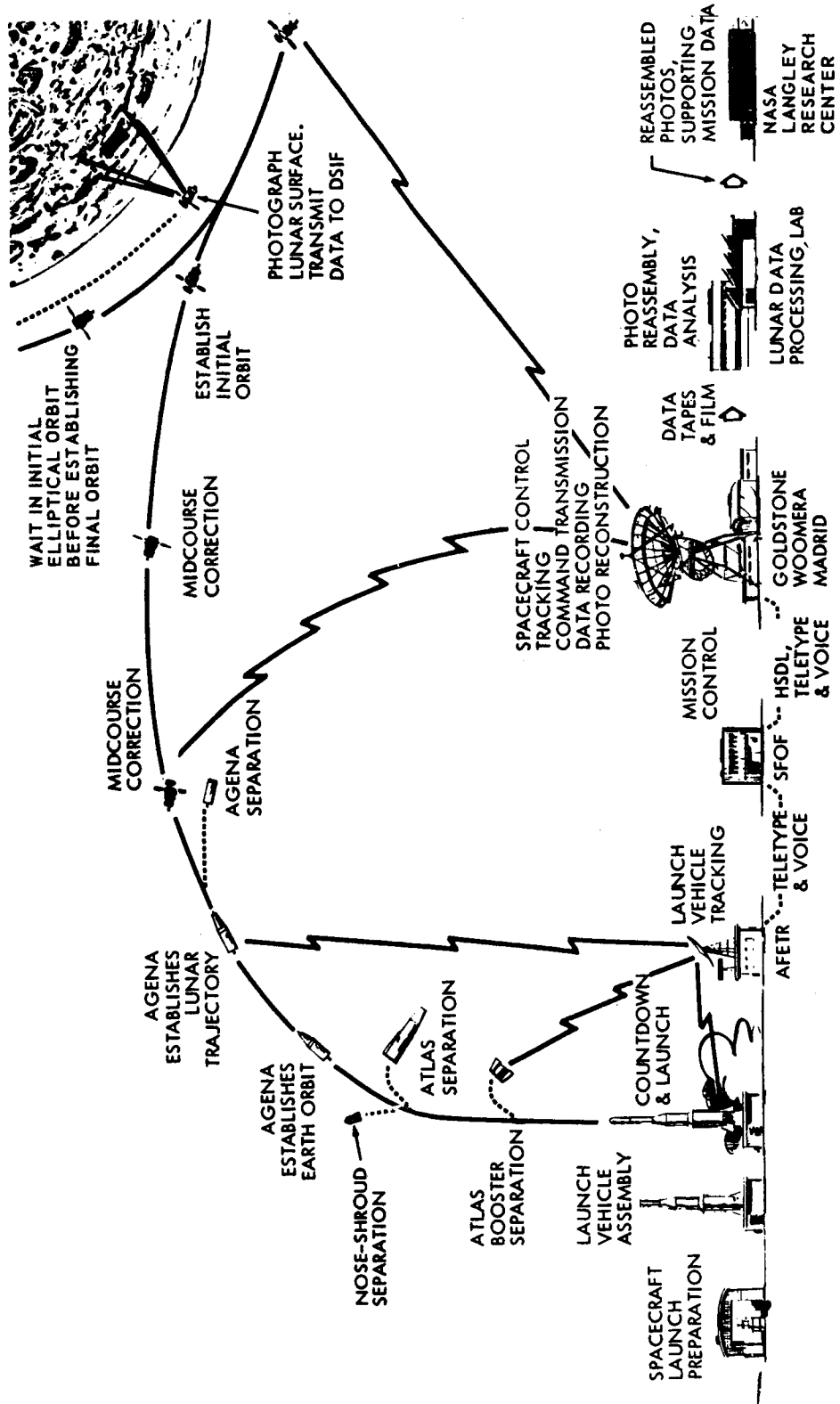

THE MISSION

Lunar Orbit Injection

During translunar flights, trajectory information provided by the Deep Space Net tracking stations will be used in the Space Flight Operations Facility to compute the velocity change required to achieve an initial lunar orbit. On a nominal mission, lunar orbit injection will occur after 89 hours of flight.

As the Lunar Orbiter more deeply penetrates the lunar gravitational field, a calculated attitude maneuver will point the rocket engine against the direction of flight. The correct burn time, as computed on the ground, will be placed in the programmer.

Then, at a precise instant, the rocket engine will ignite for a burn time of about 10 minutes if the spacecraft is on its planned trajectory. Small variations from the intended trajectory are probable, and the engine burn time will be adjusted as necessary.

The slowed spacecraft, approaching an altitude about 2,300 miles above the surface of the Moon will no longer have sufficient velocity to continue onward against the pull of lunar gravity, and will be captured as a satellite of the Moon. High point of the orbit (apolune) is intended to be 3,800 miles, with a perilune or low point about 1,650 miles. The orbit will be nearly polar, inclined about 85° to the Moon's equator. Lunar Orbiter D will require 12 hours for each circuit of the Moon in the orbit desired.

Then, after a waiting time which can vary from three days to nearly zero, depending upon the day of launch, Lunar Orbiter D will be ready to begin, on May 11, its primary task of surveying in sharp detail nearly the entire surface of the Moon.

LUNAR ORBITER AND ATLAS-AGENA TEAMS

NASA Headquarters, Washington, D.C.

Dr. Homer E. Newell	Associate Administrator for Space Science and Applications
Oran W. Nicks	Director, Lunar and Plane- tary Programs
Capt. Lee R. Scherer	Lunar Orbiter Program Manager
Leon J. Kosofsky	Lunar Orbiter Program Engineer
Dr. Martin J. Swetnick	Lunar Orbiter Program Scientist
Vincent L. Johnson	Director, Launch Vehicle and Propulsion Programs
Joseph B. Mahon	Agena Program Manager

Langley Research Center, Hampton, Va.

Dr. Floyd L. Thompson	Director
Charles J. Donlan	Associate Director
Eugene C. Draley	Assistant Director for Flight Projects
Dr. Samuel Katzoff	Chairman, Langley Research Center Lunar Orbiter Ad- visory Committee
Clifford H. Nelson	Lunar Orbiter Project Mgr.
James S. Martin, Jr.	Assistant Manager, Lunar Orbiter Project
Israel Taback	Spacecraft Manager
William I. Watson	Assembly and Integration
G. Calvin Broome	Photographic Subsystem
J.E. Harris	Power Subsystem
Royce H. Sproull	Velocity and Attitude Con- trol Subsystem
T. W. E. Hankinson	Thermal, Structure and Mechanisms Subsystem
I. W. Ramsey	Spacecraft Testing

William J. Boyer	Operations Manager
Dalton D. Webb	Space Flight Operations Director (SFOD)
Donald H. Ward	Spacecraft Launch Operations
John B. Graham	Operations Integration
Kenneth L. Wadlin	Lunar Orbiter Resident Engineer, Boeing, Seattle
Norman L. Crabill	Mission Integration Manager
A. T. Young	Mission Definition
Edmund A. Brummer	Communications and Tracking Manager
Gerald W. Brewer	Mission Assurance Manager
William L. Ervi	Department of Defense Field Support
I. G. Recant	Data Analysis Manager
Robert L. Girouard	Space Vehicle System Manager
Theodore H. Elder	Technical Administration Manager
F. E. Jennings	Funding and Schedules
<u>Lewis Research Center, Cleveland</u>	
Dr. Abe. Silverstein	Director
Dr. Seymour C. Himmel	Assistant Director for Launch Vehicles
H. Warren Flohr	Manager, Agena Project
Edward F. Baehr	Manager, Atlas Project
Joseph A. Ziemianiski	Agena Project Engineer

Kennedy Space Center, Fla.

Dr. Kurt H. Debus	Director
Robert H. Gray	Director of Unmanned Launch Operations
Harold Zweigbaum	Manager, Atlas Agena Operations

Jet Propulsion Laboratory, Pasadena, Cal.

Dr. William H. Pickering	Director
Gen. A. R. Luedecke	Deputy Director
Dr. Eberhardt Rechtin	Assistant Laboratory Director for Tracking and Data Acquisition
John Thatcher	Tracking and Data Systems Manager
J. R. Hall	Lunar Orbiter DSN Manager
Walter E. Larkin	JPL Engineer-in-Charge, Goldstone, Cal.
Howard Olson	Echo Station Manager, Goldstone
Joseph Feary	JPL Station Manager, Cebreros site, Madrid, Spain
Phil Tardani	JPL DSN Resident, Madrid
R. J. Fahnstock	JPL DSN Resident, Australia
D. Willshire	Station Manager, Woomera
Robert Terbeck	JPL DSN Resident, Johannesburg
Doug Hogg	JPL Station Manager, Johannesburg

Industrial Team

The Lunar Orbiter prime contractor is The Boeing Co., Seattle, Wash., which designed, built and tested the spacecraft. Major subcontractors to Boeing are the Eastman Kodak Co., Rochester, N. Y., for the camera system and Radio Corporation of America, Camden, N. J., for the power and communications systems.

Prime contractor for the Atlas booster stage is General Dynamics/Convair, San Diego, Calif., and prime contractor for the Agena second stage is Lockheed Missiles and Space Co., Sunnyvale, Calif.

The following is a list of other subcontractors for the Lunar Orbiter Spacecraft:

<u>Contractor</u>	<u>Product</u>
Accessory Products Company	Quad Check Valve
Ball Brothers Research Corporation	Sun Sensor
Bell Aerosystems	Fuel Tanks
Bendix Corporation	Crystal Oscillator
Calmec Manufacturing Co.	Relief Valve
J. C. Carter Company	Propellant Fill & Vent Valve
Electronic Memories, Inc.	Programmer Memory
Fairchild Controls	Pressure Transducer
Firewel Company	Fill & Test Valves
General Precision, Inc., Kearfott Division	TVC Actuator
Gerstenslager Company	Van
ITT Federal Laboratories	Star Tracker
Marquardt Corporation	Engine
National Water Lift Co.	Hi Pressure Regulator

Contractor

Product

Ordnance Engineering Associates

Pin Release Mechanism
N₂ Squib Valve
Shut Off Valve
Propellant Squib Valve
Cartridges

Radiation, Incorporated

Multiplexer Encoder
Test Set

Resistoflex Corporation

Propellant Hoses

Sperry Gyroscope Company

Inertial Reference Unit

Standard Manufacturing Company

Servicing Unit - Cart
Purge, Dry & Flush Unit

Sterer Engineering and Manufactur-
ing Company

Thrusters
Low Pressure Regulator

Texas Instruments, Inc.

Radiation Dosage
Measurement System

Vacco Valve Company

N₂ Filter
Propellant Filter

Vinson Manufacturing Co.

Linear Actuator