

# NASA TECH BRIEF



NASA Tech Briefs are issued to summarize specific innovations derived from the U.S. space program, to encourage their commercial application. Copies are available to the public at 15 cents each from the Clearinghouse for Federal Scientific and Technical Information, Springfield, Virginia 22151.

## Telescope Mount with Azimuth-Only Primary

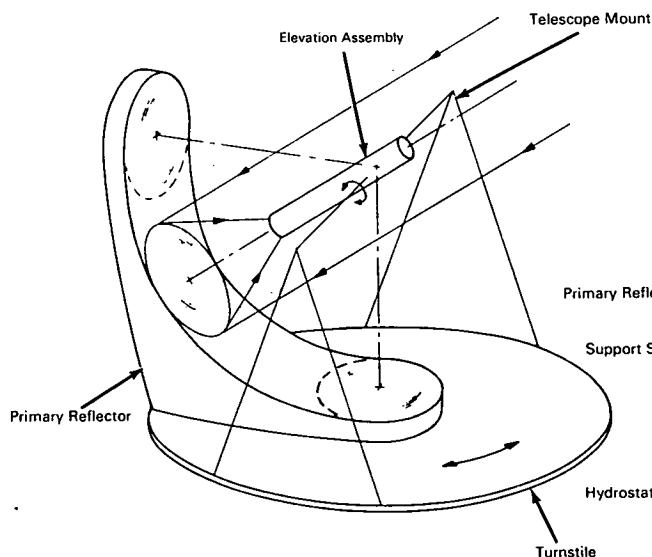

FIGURE 1

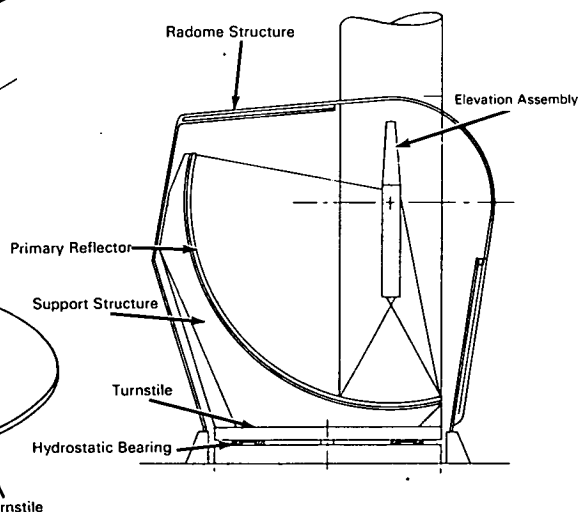

FIGURE 2

### The problem:

Large aperture telescope primary reflectors are necessarily made up of numerous segments, thus subject to distortion or misalignment when the assembly is moved. This is due to change in the center of gravity of the reflector as it is moved during a tracking operation. Although each segment may be counterweighted to minimize distortions of its individual surface, achieving accurate alignment of the segments related to each other involves complex solutions to gravity-imposed deflections of the support structure.

### The solution:

A concept based on complete avoidance of varying gravity deflection problems in the primary mirror by fixing that element of the system with respect to the gravity vector. The primary reflector does not become

distorted in various positions nor in changing positions.

### How it's done:

Figure one depicts the system schematically. The elevation assembly can operate through a  $90^\circ$  elevation angle and the area of the primary reflector need be only as large as is required by the field of view of the elevation assembly. The distance from the elevation assembly to the primary reflector places the telescope focal point near the entrance aperture of the elevation assembly.

Figure two is a plan view that shows the primary reflector, comprised of precision optically ground segments mounted in a support structure that rests on the rotating turnstile. The entire structure floats on a hydrostatic bearing for rotating in azimuth about a

(continued overleaf)

vertical axis through the center of the turnstile. The elevation assembly is pivotally mounted at the center of curvature of the primary reflector.

The entire assembly is covered by a radome structure having an opening adjacent the telescope pointing area. Conventional servomechanical means position the elements in azimuth and elevation at appropriate rates with damping commensurate with the structure size.

**Note:**

This development is in conceptual stage only, and, as of date of publication of this Tech Brief, neither a model nor prototype has been constructed.

**Patent status:**

No patent action is contemplated by NASA.

Source: Willard H. Wells  
Jet Propulsion Laboratory  
(NPO-10468)

SF  
RM. 1423  
ATTN. ATKINS  
KSC HQS.  
-1-