

December 1967

Brief 67-10646

NASA TECH BRIEF



NASA Tech Briefs are issued to summarize specific innovations derived from the U.S. space program, to encourage their commercial application. Copies are available to the public at 15 cents each from the Clearinghouse for Federal Scientific and Technical Information, Springfield, Virginia 22151.

Improved Magnetic Tape Recorder

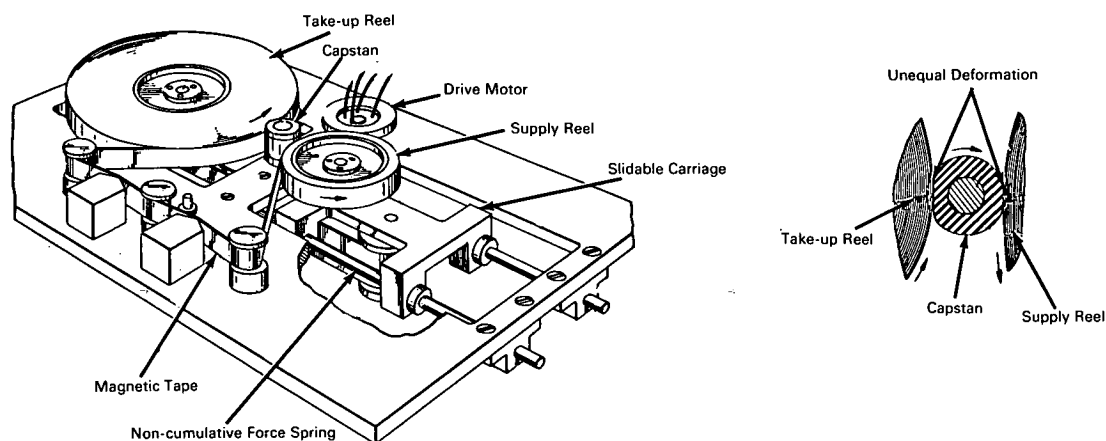

A magnetic tape recorder, which has been designed, is of simple, rugged construction and operates with relatively little power.

Conventional direct drive mechanisms for magnetic tape recorders incorporate a friction brake for the supply reel, which tends to increase power consumption and is subject to failure due to wear and severe environmental conditions. In alternative designs, endless belts employed to avoid friction braking of the supply reel are subject to fatigue failure and non-uniform strains along their lengths, which result in nonuniform driving of the reels.

The new tape recorder design employs a single capstan for simultaneously driving the supply and take-up reels in such a manner that the tape passing between the reels is kept under a predetermined constant tension. This recorder operates with little power and is sufficiently rugged to withstand the severe stresses encountered in high-altitude balloon flight tests.

The capstan has a resilient, deformable cylindrical drive surface (such as rubber) which directly couples

and simultaneously drives the supply and take-up reels by frictional surface engagement with the outer layer of tape carried on the periphery of each reel. The reels are supported on slidable carriages (carriage for take-up reel not visible in illustration). Non-cumulative force springs (only one of two visible in illustration) control the movement of the carriages with respect to the capstan. The first non-cumulative force spring (illustrated) directly couples the two carriages to maintain the tape reels in driven engagement with the capstan, even if unbalancing forces are encountered during recorder operation. The second spring maintains a greater contact force between the capstan and the tape carried on the take-up reel than on the supply reel, resulting in the unequal deformation of the capstan surface shown in the auxiliary view. This unequal deformation results in a differential in speed between the two reels so that the tape transferred to the take-up reel is subjected to a predetermined constant tension. Power consumption is reduced because of the absence of a conventional friction brake for the supply reel.

(continued overleaf)

Notes:

1. By providing additional force springs for each tape reel with a means to selectively disconnect the springs, a machine having both recording and play-back capabilities will be obtained.
2. Inquiries concerning this invention may be directed to:

Technology Utilization Officer
Goddard Space Flight Center
Greenbelt, Maryland 20771
Reference: B67-10646

Patent status:

Inquiries about obtaining rights for the commercial use of this invention may be made to NASA, Code GP, Washington, D.C. 20546.

Source: Paul W. Uber
(XGS-08259)