

NASA TECH BRIEF

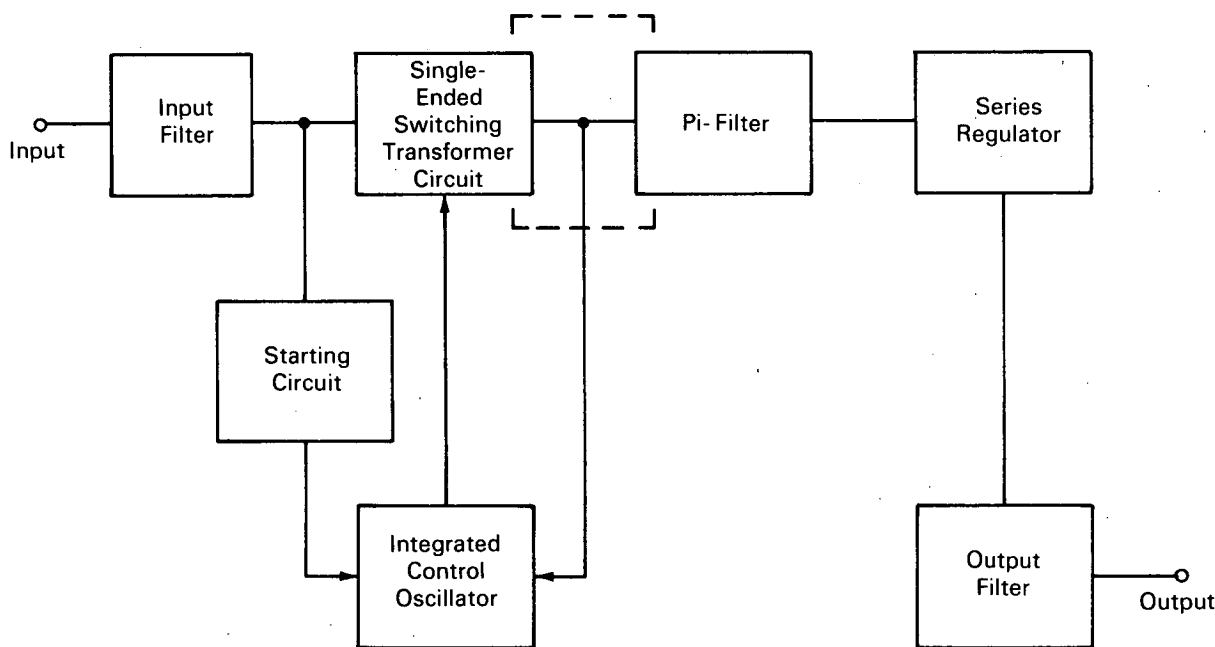

NASA Tech Briefs are issued to summarize specific innovations derived from the U.S. space program, to encourage their commercial application. Copies are available to the public at 15 cents each from the Clearinghouse for Federal Scientific and Technical Information, Springfield, Virginia 22151.

Solid State Single-Ended Switching DC-to-DC Converter



The problem:

In many circuit applications, a dc supply is required to be electrically isolated from the prime dc power source. Such isolation is normally obtained by means of a dc-to-dc converter involving several stages consisting of rather complex circuitry.

The solution:

A solid state, single-ended switching dc-to-dc converter that provides a highly regulated, electrically isolated dc output voltage with only one power stage.

How it's done:

The converter may be divided into seven distinct subcircuits as illustrated in the block diagram. The

series regulator is required only where precise regulation must be had. The input and output filters are included specifically to enhance the electromagnetic compatibility of the converter and thus meet rather stringent radio frequency interference requirements.

The starting circuit performs two functions: it assures that the on time of its output transistor is of sufficient duration to start the integrated control oscillator at the lower temperature limit of -20°C ; and it assures that the off time is long compared to the on time of the power transistor in the single-ended switching transformer circuit. In the integrated control oscillator, an astable multivibrator coupled with an integrated high performance operational amplifier, is used to control the operating frequency of

(continued overleaf)

the converter, and thus, to regulate the output voltage.

Output voltage ripple associated with the converter storage capacitor is partially controlled by selecting a capacitor with a low dissipation factor and further decreased by adding an inductive-capacitive Pi-filter to this circuitry. The series regulator is designed to provide the desired regulation although a slight decrease in overall converter efficiency results from its use. It provides a high frequency cutoff and a decreased output impedance at the higher operating frequencies.

Notes:

1. Output voltage is within $\pm 0.325\%$ of the nominal 28 vdc output voltage over the complete design temperature, load, and input voltage ranges. The converter has a maximum dc output impedance of 0.1021Ω and maintains an overall efficiency of approximately 80% under all operating conditions.

2. Inquiries concerning this innovation may be directed to:

Technology Utilization Officer
Marshall Space Flight Center
Huntsville, Alabama 35812
Reference: B67-10558

Patent status:

No patent action is contemplated by NASA.

Source: M. A. Honnell
of Auburn University
under contract to
Marshall Space Flight Center

(MFS-13598)