

December 1967

Brief 67-10540



AEC-NASA TECH BRIEF



AEC-NASA Tech Briefs describe innovations resulting from the research and development program of the U.S. AEC or from AEC-NASA interagency efforts. They are issued to encourage commercial application. Tech Briefs are published by NASA and may be purchased, at 15 cents each, from the Clearinghouse for Federal Scientific and Technical Information, Springfield, Virginia 22151.

Automatic Transducer Switching Provides Accurate Wide Range Measurement of Pressure Differential

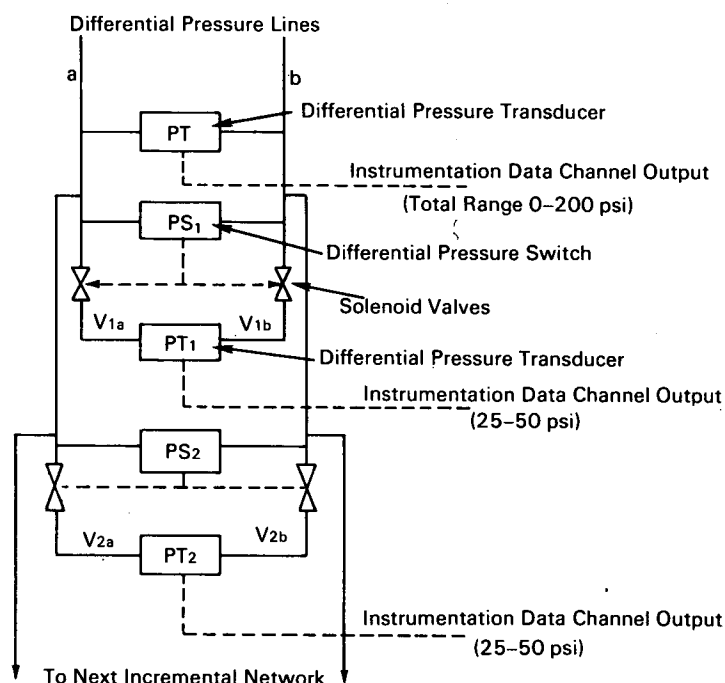

The problem:

To measure differential gas pressure over a wide range (0-200 psi) but with great accuracy at any point in the scale. High precision transducers usually are limited in the range of measurement and can be easily damaged if the pressure limits are exceeded.

The solution:

An automatic pressure transducer switching network which sequentially selects any one of a number of limited-range transducers as the pressure rises or falls.

How it's done:

In operation, where no differential pressure exists across lines a and b, the two normally open solenoid valves V_{1a} and V_{1b} are open. As the a-b differential pressure rises, it is measured by transducer PT_1 (shown as 0-25 psi) until the 25 psi limit is reached. At this point, as detected by pressure switch PS_1 , PS_1 closes valves V_{1a} and V_{1b} to prevent further gas flow to PT_1 . The pressure is still applied to the next ramp (PS_2 , V_{2a} , V_{2b} , and PT_2) which is set for the 25-50 psi range. Additional networks are added to the

(continued overleaf)

system to complete the total incremental coverage. Transducer PT provides full range, but less accurate, monitoring of the pressure activity.

Notes:

1. The 0-200 psi range and 25 psi incremental steps were selected only for discussion purposes. Greater ranges and more or less precise incremental steps are entirely feasible.

2. Inquiries concerning this innovation may be directed to:

Technology Utilization Officer
AEC-NASA Space Nuclear
Propulsion Office
U.S. Atomic Energy Commission
Washington, D.C. 20545
Reference: B67-10540

Patent status:

No patent action is contemplated by AEC or NASA.

Source: S. K. Yoder
of Aerojet-General Corp.
under contract to
AEC-NASA Space Nuclear Propulsion Office
(NUC-10001)