

July 1967

Brief 67-10260

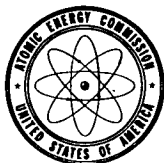

AEC-NASA TECH BRIEF



AEC-NASA Tech Briefs describe innovations resulting from the research and development program of the U.S. AEC or from AEC-NASA interagency efforts. They are issued to encourage commercial application. Tech Briefs are published by NASA and may be purchased, at 15 cents each, from the Clearinghouse for Federal Scientific and Technical Information, Springfield, Virginia 22151.

Tester Automatically Checks Insulation of Individual Conductors in Multiple-Strand Cables

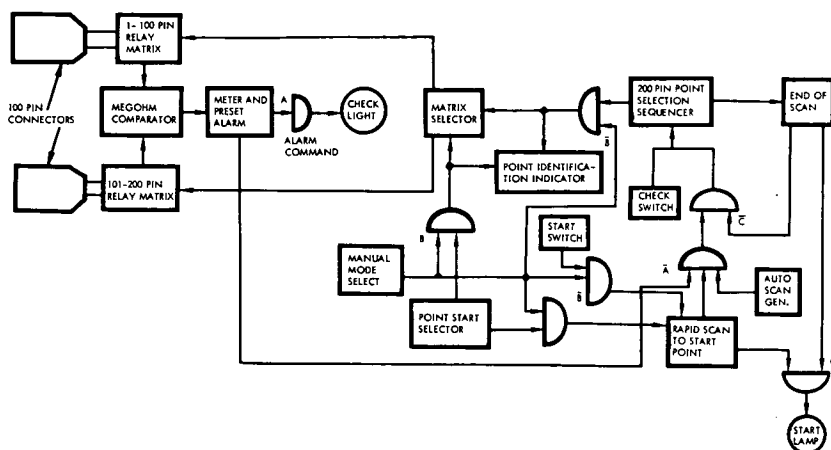
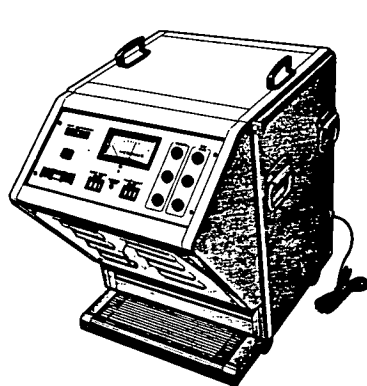

The problem:

The testing of nuclear rocket reactors requires the use of multiple-strand electrical cables for the connection of instruments, transducers, terminal boards, etc. The integrity of the insulation in each cable circuit must be checked periodically to ensure accurate test results. Manual checking is a tedious and time-consuming operation.

The solution:

A cable insulation tester with both manual and automatic capabilities that can check the insulation of each conductor in a multiple-strand cable containing up to 200 or more conductors in a few minutes.

How it's done:

The cable insulation tester consists of two relay matrices, a combination megohm and low alarm comparator, and associated readout and control systems. The comparator consists of a regulated dc power supply with outputs of 10, 50, or 500 volts, a set of

ranging precision resistors, and a transistorized meter amplifier. An optical meter relay performs both the functions of resistance value readout and alarm. The unit has two modes of operation: manual and automatic.

In the manual mode, any one pin may be selected by dialing the corresponding number on the point switch located on the control panel. This activates the corresponding matrix relay. The point under test then appears on the point identification indicator, and its resistance, in relation to the other pins, is displayed on the ohmmeter.

In the automatic mode of operation, each pin within the preselected interval is subsequently referenced to all other pins which are grounded. If the resistance value falls below a preset resistance value, the scan is stopped by the comparator at the alarm point, a lamp in the check switch is lighted, and the point identification indicator displays the pin number in question.

(continued overleaf)

When the switch is depressed, the scan continues from the pin following the alarmed pin until either another alarmed pin or the end of the scan is reached.

Notes:

1. The tester can check 200 pins directly, or more by the use of suitable adapters, if required. The instrument is compact, portable, mounted on wheels, and operates on 115 volt, 60 cycle power.
2. Inquiries concerning this innovation may be directed to:

AEC-NASA Space Nuclear Propulsion
Office
U.S. Atomic Energy Commission
Washington, D.C. 20545
Reference: B67-10260

Patent status:

No patent action is contemplated by AEC or NASA.

Source: Michael Vuckovich and Jack Shaw
of the Westinghouse Astronuclear Laboratory
under contract to
Space Nuclear Propulsion Office
(NUC-10068)