

NASA TECH BRIEF

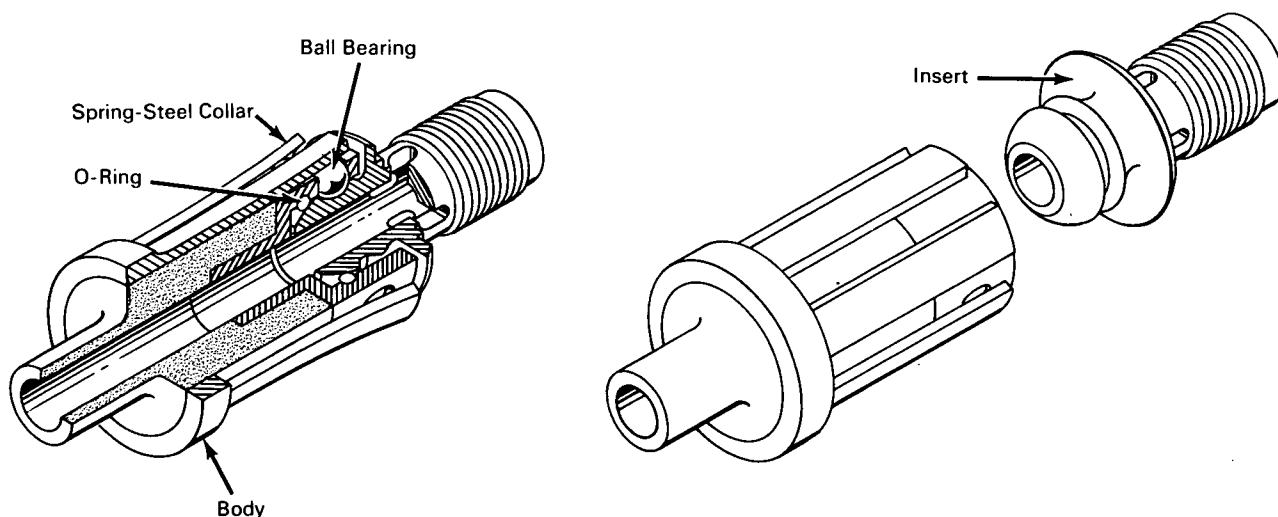

NASA Tech Briefs are issued to summarize specific innovations derived from the U.S. space program, to encourage their commercial application. Copies are available to the public at 15 cents each from the Clearinghouse for Federal Scientific and Technical Information, Springfield, Virginia 22151.

Line Adapter Provides Quick Disconnect Under Moderate Side Loading



The problem:

To provide a quick and simple line disconnect system, separable by a predetermined side loading under given pressure.

The solution:

A line adapter that quickly separates upon the application of a side load of 15 lbs with standing line pressure at 100 psig.

How it's done:

The unit consists of a cylindrical female adapter and a ball-shaped male insert. The adapter is placed inside of a spring steel collar that is machined to form equally spaced torques, retaining a number of staked ball bearings. These spring-loaded balls act to lock into a groove, machined in the male insert, as connection is made.

For sealing purposes, an O-ring is retained inside the adapter.

Note:

Inquiries concerning this innovation may be directed to:

Technology Utilization Officer
Marshall Space Flight Center
Huntsville, Alabama 35812
Reference: B67-10256

Patent status:

No patent action is contemplated by NASA.

Source: E. A. Wolfram
of North American Aviation, Inc.
under contract to
Marshall Space Flight Center
(M-FS-2159)

Category 05