

July 1967

Brief 67-10220

NASA TECH BRIEF



NASA Tech Briefs are issued to summarize specific innovations derived from the U.S. space program, to encourage their commercial application. Copies are available to the public at 15 cents each, from the Clearinghouse for Federal Scientific and Technical Information, Springfield, Virginia 22151.

Low Speed, Long Term Tracking Electric Drive System Has Zero Backlash

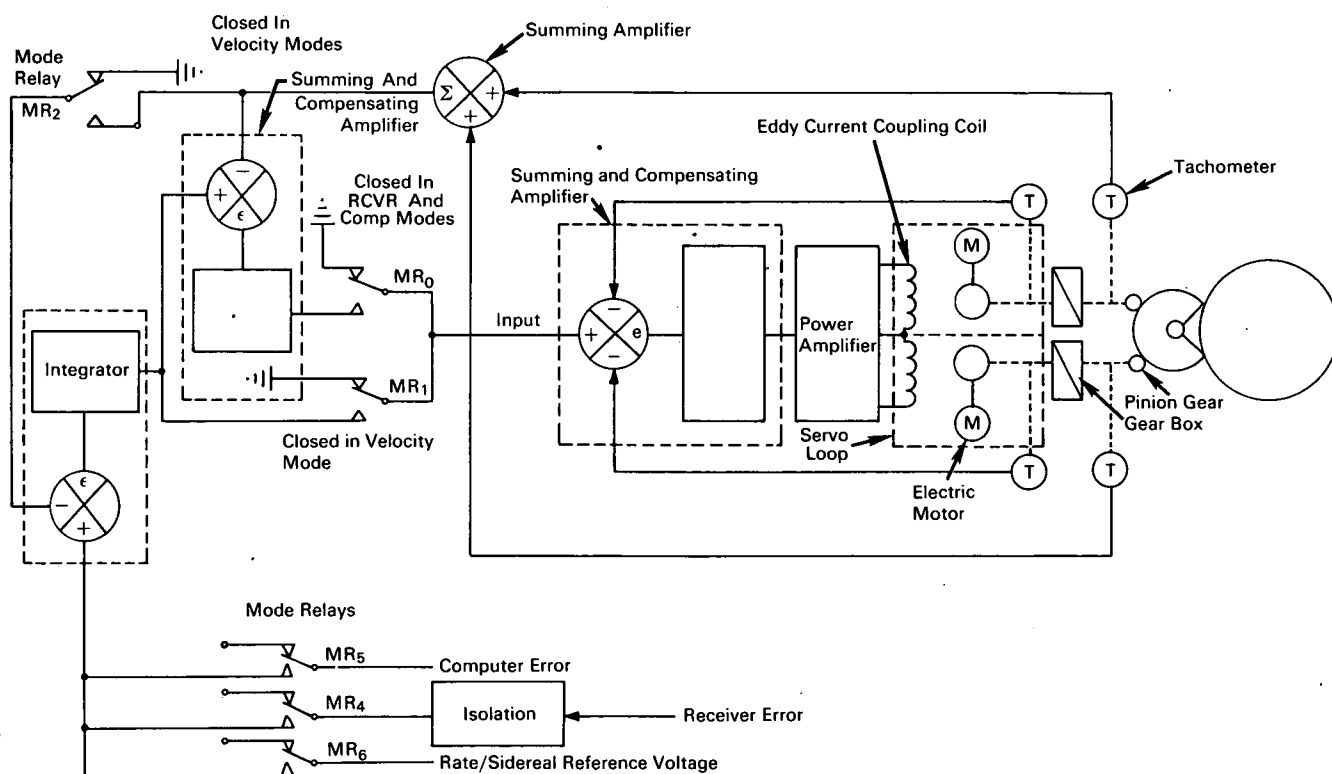

The problem:

To develop an electric drive system that will provide low speed, long term tracking of space probes, stars, and other targets that move at a sidereal rate. The system must be capable of moving a large structure, such as an 85-foot tracking antenna, a specified distance with essentially zero backlash, and without generating electrical noise and radio frequency interference. Prior art drive devices used silicon controlled rectifiers which caused radio frequency interference.

The solution:

An electric drive system that utilizes eddy-current energized actuators that are free from radio frequency interference generation and a solid state feedback amplifier with provisions for antibacklash biasing.

How it's done:

The electric drive system contains four primary servo loops: a current feedback loop, a motor rate loop, a pinion rate loop, and velocity and position

(continued overleaf)

loops. The current feedback loop serves to decrease the effective inductive time constant of the large inductance inherent in the eddy-current coupling within the actuator by utilizing a feedback of the current in the actuator coil. The current loop is closed with an open loop gain such that the effective time constant of the eddy-current field coil is reduced to 0.01 second.

The motor rate loop comprises an eddy-current actuator, tachometer, summing and compensating amplifier, power amplifier, and eddy-current coupling coil which controls the amount of torque transferred from the constant speed electric motor to the eddy-current coupler to the output shaft and gear box.

A servo loop operating in opposition comprises an eddy-current actuator, tachometer, summing and compensating amplifier, power amplifier, and eddy-current coupling coil which controls torque transfer from the electric motor to the gear box. The antibacklash feature is inherent in this design since some power is applied to the dragging actuator when its opposite is driving the load. A bipolar dc signal, applied to the input of the differential network, controls the direction of the drive of the motor rate loop.

A pinion-rate loop operates in conjunction with the motor rate loop. The pinion-rate loop provides for damping of the gearboxes and senses the motion of the antenna. The upper pinion gear, which drives the antenna, is physically coupled to the upper tachometer. Similarly, the lower pinion gear and lower tachometer are coupled. The output (rate of speed) of these tachometers is summed in the summing amplifier, the output of which closes the pinion rate loop through the summing and compensating amplifier, or through the upper left mode relay and integrator when in one of the velocity modes of operation. When in the position modes of operation, the pinion rate signal closes a conventional rate loop around the

pinion but in the velocity modes this signal, when summed with a rate reference, provides the error necessary for precise rate control.

In the receiver and computer modes (position loop), error signals are derived from receiver output or antenna axis resolvers respectively. The error signal is transferred through mode relays MR4 or MR5 directly into the integrator and then summed with the pinion rate signal in the summing and compensating amplifier.

Notes:

1. The drive system does not generate noise that could interfere with reception of very low level radiometry or space probe signals. The system is capable of multimode operation in that signals from several sources can be integrated to control the overall motion of the structure.
2. The system is compatible with electrohydraulic systems for slewing.
3. This drive system may be used to advantage wherever several signals must be combined to move a large structure a specified distance and where backlash is not tolerable. Such applications may include large machine tools controllable by analog or digital-to-analog devices.
4. Inquiries concerning this innovation may be directed to:

Technology Utilization Officer
NASA Pasadena Office
4800 Oak Grove Drive
Pasadena, California 91103
Reference: B67-10220

Patent status:

No patent action is contemplated by NASA.

Source: Hans L. Richter and Floyd W. Stoller
Jet Propulsion Laboratory
(NPO-10173)