

June 1967

Brief 67-10199

NASA TECH BRIEF



NASA Tech Briefs are issued to summarize specific innovations derived from the U.S. space program, to encourage their commercial application. Copies are available to the public at 15 cents each from the Clearinghouse for Federal Scientific and Technical Information, Springfield, Virginia 22151.

Electrometer Amplifier Operates Over Dynamic Range of Five Orders of Magnitude

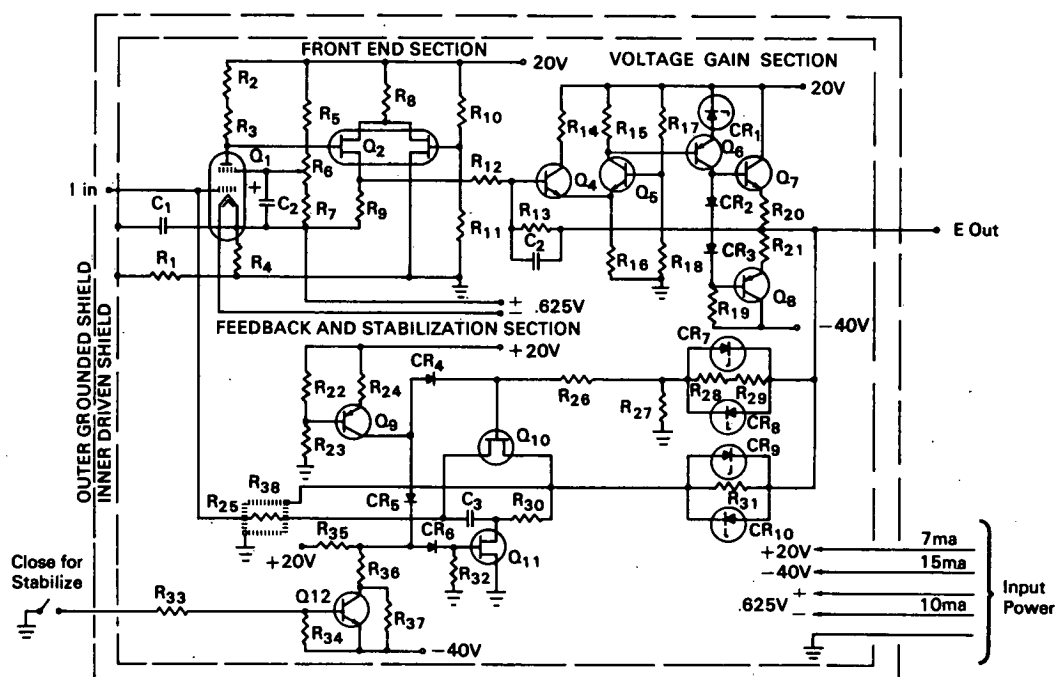

The problem:

To design an electrometer amplifier which would be capable of operation over a dynamic range of five orders of magnitude. An amplifier with these characteristics was required to detect currents in the Pioneer plasma probe experiment, with low power consumption, small offset error, and good frequency response.

The solution:

A special purpose electrometer amplifier which covers five orders of magnitude dynamic range, which converts positive (ion) currents in the range of 10^{-14} to 10^{-9} ampere to a corresponding voltage in the

range of $+0.006$ volt dc to -30.0 volts dc, and negative (electron) currents in the range 10^{-14} to 10^{-10} ampere to a corresponding voltage in the range of $+0.006$ volt dc to $+10$ volts dc.

How it's done:

The five-order magnitude of dynamic range of the device is achieved by incorporating a zener controlled attenuator in the feedback path for the amplifier. When the breakpoint voltage of the diode is reached, part of the attenuator circuit is shorted out, thus modifying the overall gain of the amplifier to extend the range.

(continued overleaf)

The frequency response of the amplifier is enhanced by packaging the system in a driven shield which is at the same potential as the pickup target. This technique effectively reduces the input capacity to the electrometer. Similarly, the high valued (2×10^{10} ohms) resistor used in the feedback path is shielded by a wound solenoid operated at a potential to cancel the distributed capacities of the feedback resistor.

Long term drift is minimized by periodic stabilization of the amplifier from external commands. The stabilization network included in the feedback loop employs a capacitive network for accumulating and storing the error caused by drift between periods of stabilization. On command, this error signal is referred back to the input to effectively cancel out the drift error signal of the amplifier.

Notes:

1. Listed below are the final specifications for the nonlinear dc periodically stabilized electrometer amplifier as developed:
 - A. Current Range: 10^{-14} to 10^{-9} amp (ion);
 10^{-14} to 10^{-10} amp (electron)
 - B. Noise: 10^{-14} amp rms (max)
 - C. D-C Offset: 10^{-14} amp (max)
 - D. Drift between stabilization cycles for input currents below 10^{-11} amp: 3×10^{-16} amp/sec (max)

- E. Long term stability: $\pm 2\%$ (max)
- F. Temperature stability: $\pm 5\%$ (max)
- G. Frequency Response: 30 Hz
- H. Transresistance (R):

(1) for $i_1 < 1.2 \times 10^{-11}$ amp $\pm 5\%$

$$R = \frac{e_0}{i_1} = 6 \times 10^{-11} \frac{\text{ohm}}{\text{amp}} \pm 5\%$$

(2) for $i_1 > 1.2 \times 10^{-11}$ amp $\pm 5\%$

$$R = \frac{e_0}{i_1} = 2 \times 10^{10} + \frac{6.96}{i_1} \text{ ohms } \pm 5\%$$

2. Additional technical details are available from:
Technology Utilization Officer
Ames Research Center
Moffett Field, California 94035
Reference: B67-10199

Patent status:

Inquiries about obtaining rights for the commercial use of this invention may be made to NASA, Code GP, Washington, D.C. 20546.

Source: Norman Katz
of Marshall Laboratories
under contract to
Ames Research Center

(ARC-75)