

March 1967

Brief 67-10052



# AEC-NASA TECH BRIEF



AEC-NASA Tech Briefs describe innovations resulting from the research and development program of the U.S. AEC or from AEC-NASA interagency efforts. They are issued to encourage commercial application. Tech Briefs are published by NASA and may be purchased, at 15 cents each, from the Clearinghouse for Federal Scientific and Technical Information, Springfield, Virginia 22151.

## Laboratory Arc Furnace Features Interchangeable Hearths

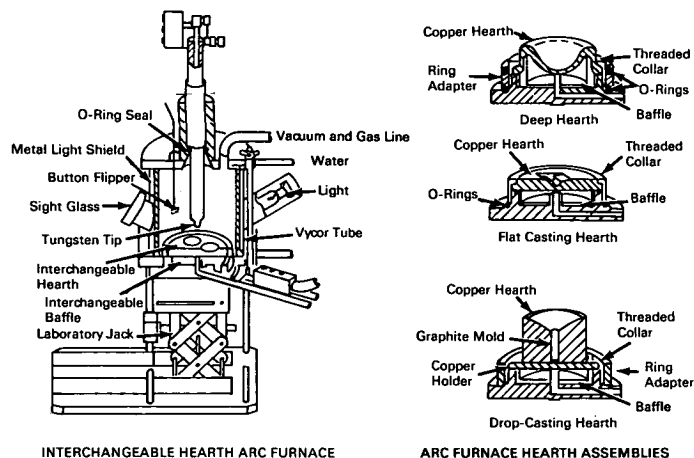

INTERCHANGEABLE HEARTH ARC FURNACE

ARC FURNACE HEARTH ASSEMBLIES

### The problem:

To develop a laboratory arc furnace that can handle a variety of casting problems. The furnace must make several buttons at one time, or cast a variety of shapes, provide for observation of the melt, and allow for easy disassembly and cleaning. Current arc furnace designs which have a single-purpose hearth are limited in their casting capabilities.

### The solution:

A simply constructed laboratory arc furnace using rapidly interchangeable hearths. The hearths provide the furnace with considerable versatility in casting so that buttons or special shaped castings can be produced. The furnace also features a sight glass which provides for observation of the hearth.

### How it's done:

The furnace has three major sections: the main body, the interchangeable hearths and baffles, and the laboratory jack-loading device. The main body of the furnace is supported on four brass posts fastened to a lower plate. This design allows the hearth, which is

mounted on the laboratory jack, to be lowered and pulled toward the operator. The bottom of the furnace is insulated from its top by a Vycor tube which is sealed at both ends with water-cooled neoprene gaskets. A sight glass and small light are mounted in metal light shields to permit the operator to view the hearth. A button flipper which is used in conjunction with the electrode extends through the top seal of the Vycor tube for the purpose of turning buttons over without having to open the furnace. A water-cooled vertical electrode is mounted on a ball joint, providing horizontal positioning of the electrode tip to all parts of the hearth. The threaded upper portion of the electrode passes through an internally threaded insulating sleeve. Vertical positioning of the electrode is accomplished by rotation of this sleeve. An O-ring seal, compressed against the electrode by tightening of the ball joint nut, achieves a leaktight seal, even during movement of the electrode.

The interchangeable copper hearths are held to a cooling cavity by a stainless steel threaded collar. One of the two baffle configurations, depending on which

(continued overleaf)

hearth is used, is placed between the hearth and the cooling cavity to achieve cooling, to provide proper water distribution, and to eliminate any bubbles formed under the hearth. Several types of interchangeable hearths are easily fabricated and used with this furnace. A flat hearth with three shallow impressions can be used to make up to three small buttons at a time. A deep hearth can be used for large buttons. Two other hearths are used for casting cylindrical samples and drop-casting rods to required diameters.

Disassembly for cleaning of the furnace is accomplished by unscrewing the electrode from the insulating sleeve in the top of the furnace, removing the top of the furnace, and taking out the Vycor tube. The interchangeable hearth can be lowered and pulled toward the operator for cleaning.

**Notes:**

1. Melting is done in an atmosphere of helium, argon, or a mixture of these gases. Standard welding grade gases can be used. A high-purity melt can be achieved by purging the furnace several times with inert gas and placing a zirconium "getter" button on the hearth.
2. Relatively slow cooling of the furnace can be achieved by evacuating the arc furnace (to a vacuum) immediately after melting. This is accomplished by the use of quick opening ball valve.

3. The furnace is constructed so that it may be easily operated, disassembled, and cleaned in an environmental control chamber or glove box.
4. Additional details are contained in *Review of Scientific Instruments*, Vol. 35, No. 2, February, 1965, pp. 156-158.
5. Inquiries concerning this innovation may be directed to:

Office of Industrial Cooperation  
Argonne National Laboratory  
9700 South Cass Avenue  
Argonne, Illinois 60439  
Reference: B67-10052

Source: O. L. Kruger, Metallurgy Division  
J. L. Armstrong, Central Shops  
(ARG-125)

**Patent status:**

Inquiries about obtaining rights for commercial use of this innovation may be made to:

Mr. George H. Lee, Chief  
Chicago Patent Group  
U.S. Atomic Energy Commission  
Chicago Operations Office  
9800 South Cass Avenue  
Argonne, Illinois 60439