

December 1966

Brief 66-10708



AEC-NASA TECH BRIEF



AEC-NASA Tech Briefs describe innovations resulting from the research and development program of the U.S. AEC or from AEC-NASA interagency efforts. They are issued to encourage commercial application. Tech Briefs are published by NASA and may be purchased, at 15 cents each, from the Clearinghouse for Federal Scientific and Technical Information, Springfield, Virginia 22151.

Air Bearing Provides Friction-Free Support for Shaker System Slip Table

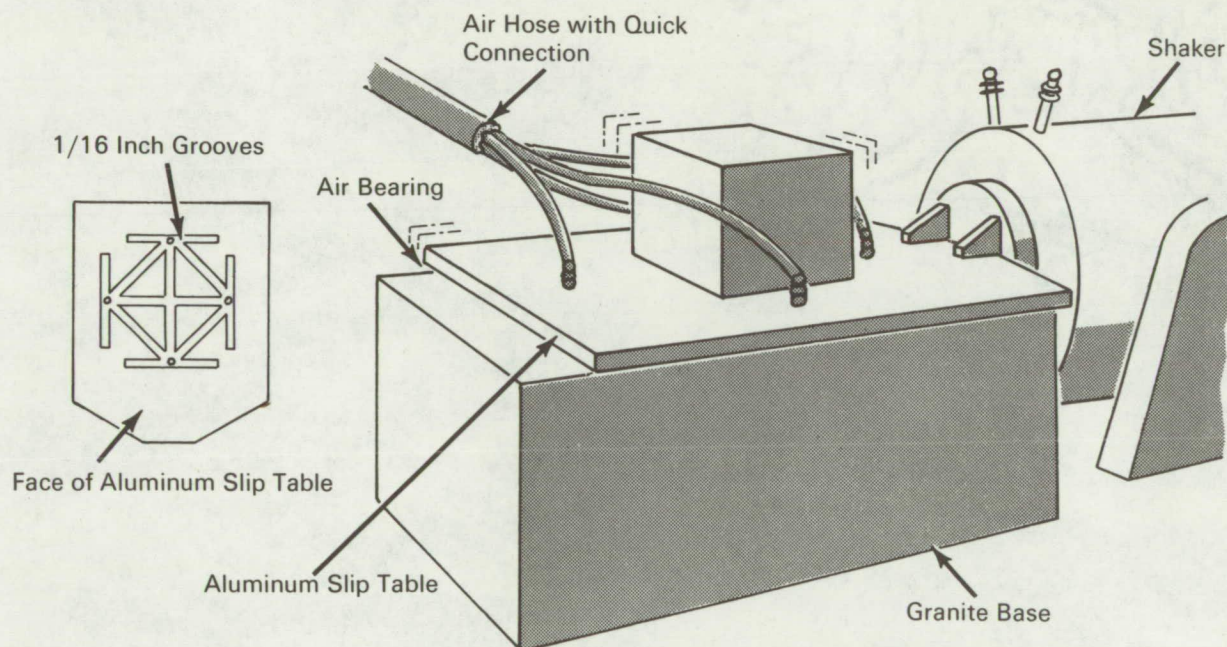

The problem :

To develop a bearing system to support a shaker system slip table with a minimum of friction. A typical vibration testing shaker system utilizes a granite base on which an aluminum slip table is supported on an oil film. The equipment to be vibration tested is rigidly bolted to the slip table, and the shaker inducer is also coupled directly to the slip table. Lubricant has to be continuously added as it flows around the edges of the granite base. In time, severe galling and wear is seen on the face of the slip table adjacent to the granite base.

The solution :

A series of 1/16-inch grooves on the face of the slip table. These grooves form a square traversed by diagonals. At each corner of the square, a 1/4-inch hole is drilled through the table and fitted with air connections. Air pressure is simultaneously fed to the four fittings forming an air bearing.

How it's done :

The face of the aluminum slip table adjacent to the granite base is modified as shown. A manifold supplies pneumatic air pressure to the four air holes. The

(continued overleaf)

air pressure supplied is proportional to the weight of the equipment package bolted to the slip table. In use, the top of the granite base and the face of the aluminum slip table are carefully cleaned prior to use. A thin film of oil is placed on the granite base. The oil film serves to prevent leakage of air pressure.

Notes:

1. Aluminum slip tables, 4 feet × 4 feet × 1-1/2 inches have been successfully modified and operated with this system.
2. Air pressure of 14 psi has been found to be sufficient to float a slip table with a 30,000 pound equipment package bolted to it.

3. Inquiries concerning this innovation may be directed to:

Technology Utilization Officer
AEC-NASA Space Nuclear Propulsion
Office
U.S. Atomic Energy Commission
Washington, D.C. 20545
Reference: B66-10708

Patent status:

No patent action is contemplated by AEC or NASA.

Source: R. W. Skoff
of Westinghouse Astronuclear Laboratory
under contract to
AEC-NASA Space Nuclear Propulsion Office
(NU-0086)