

December 1966

Brief 66-10690

NASA TECH BRIEF



NASA Tech Briefs are issued to summarize specific innovations derived from the U.S. space program, to encourage their commercial application. Copies are available to the public at 15 cents each from the Clearinghouse for Federal Scientific and Technical Information, Springfield, Virginia 22151.

Equivalent Circuit for a Field Effect Transistor Established for Computer Simulation

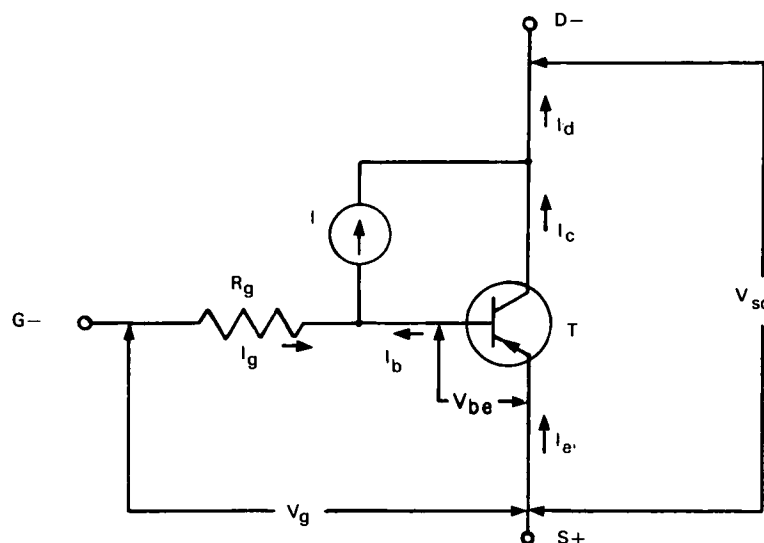

The problem:

To provide a computer simulation for a field effect transistor. Existing computer programs which perform automated electrical circuit analyses and syntheses are only able to simulate resistors, voltage and current sources, diodes, capacitors, inductors, and conventional transistors.

The solution:

An equivalent circuit for the field effect transistor made up of circuit elements which can be simulated by existing computer programs.

How it's done:

The field effect transistor equivalent circuit consists of a conventional transistor (T), a resistor (R_g),

and a constant current source (I). The terminals S, G, and D correspond to the source, gate, and drain terminals of the field effect transistor. The value of R_g is made to be the same as the gate input resistance. The value of I must be calculated from the electrical characteristics of the field effect transistor. Transistor T will be a PNP type for a P-type channel field effect transistor, and an NPN type for an N-type channel. Because computer programs simulate transistors by the I_c vs V_{be} characteristic curve, the values for I_c , V_{be} , and β must be calculated for the transistor.

Depending on the accuracy required by the application, improvements to the model may be made by including some or all of the factors which influence

(continued overleaf)

performance characteristics of the field effect transistor. These factors are:

1. Adjust the characteristics of the base-collector junction to improve the drain current curve in the pinch-off region.
2. Vary the value of R_g with variation in V_g to cause the slope of the drain current curve to vary with gate voltage.
3. Vary both R_g and β with temperature.
4. Vary β with drain current.

These factors may also be described by curves in the computer program instead of by fixed parameters.

Note:

Inquiries concerning this innovation may be directed to:

Technology Utilization Officer
Marshall Space Flight Center
Huntsville, Alabama 35812
Reference: B66-10690

Patent status:

No patent action is contemplated by NASA.

Source: L. J. Ming
of International Business Machines, Inc.
under contract to
Marshall Space Flight Center
(M-FS-1752)