

December 1966

Brief 66-10672

NASA TECH BRIEF



NASA Tech Briefs are issued to summarize specific innovations derived from the U.S. space program, to encourage their commercial application. Copies are available to the public at 15 cents each from the Clearinghouse for Federal Scientific and Technical Information, Springfield, Virginia 22151.

Resonant Frequency Can Be Adjusted on Vibration Mount

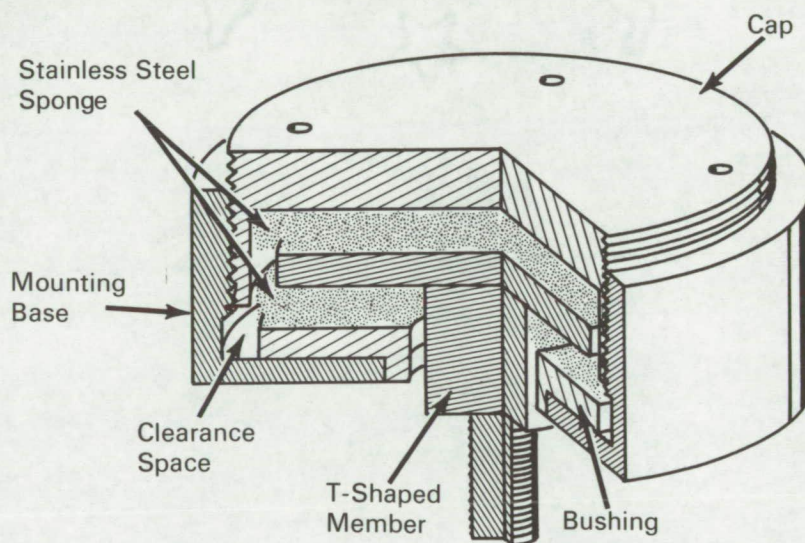

The problem:

To design a vibration mount that allows adjustment of its resonant frequency and is insensitive to a wide temperature variation.

The solution:

A mount that is essentially a multidirectional, frictionally damped spring with an adjustable cap.

How it's done:

The vibration mount has a cylindrical base and internal threads on the cylinder walls. A circular T-shaped member is mounted within the base and through a bushing. A stainless steel sponge material is bonded to the upper and lower surfaces of the wide portion of the T-shaped member. A cylindrical cap is screwed into the base as shown. The vibration

damping is provided by the physical interference of the sponge material with itself. Tightening or loosening the adjustable cap against the sponge material allows adjustment of the resonant frequency.

Notes:

1. The mount provides vibration isolation in both compression and shear.
2. The mount may be fabricated with material to make it acceptable for space application where outgassing is a problem.
3. This development is in conceptual stage only, and as of date of publication of this Tech Brief, neither a model nor prototype has been constructed.

(continued overleaf)

Patent status:

No patent action is contemplated by NASA.

Source: Fielding Hodges
of Ryan Aeronautical
under contract to
Jet Propulsion Laboratory
(JPL-SC-134)