

December 1966

Brief 66-10642

# NASA TECH BRIEF



NASA Tech Briefs are issued to summarize specific innovations derived from the U.S. space program, to encourage their commercial application. Copies are available to the public at 15 cents each from the Clearinghouse for Federal Scientific and Technical Information, Springfield, Virginia 22151.

## Device Measures Reaction Engine Thrust Vector Deviations

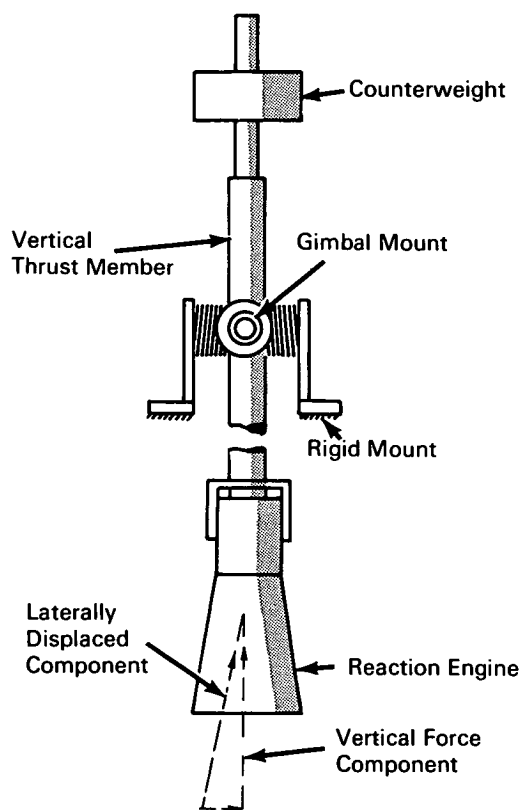

### The problem:

In the design of reaction engines for use in propelling loads through the atmosphere or in space, it is necessary to have test equipment to accurately determine the true thrust vector of each engine. Load cells mounted in three mutually orthogonal axes have been used in the past but these are subject to drift

and hysteresis, are expensive, and result in a complex test facility.

### The solution:

A gimbal mounted test device that measures thrust vector deviation in terms of angular displacement and thus precludes force interaction.

(continued overleaf)

**How it's done:**

A gimbal mount is rigidly supported and, in turn, supports a vertical thrust transmitting member in such a way that it is free to rotate in any direction. A reaction engine is mounted to the base of the vertical thrust member and an adjustable counterweight is attached to the member above the gimbal mount. This counterweight may be moved up and down to locate the assembly center of gravity in the desired location below the gimbal mount.

With the reaction engine fixed, it is possible that the direction of thrust is not precisely vertical, but may be laterally displaced. In this case, the direction of force represented by the laterally displaced component arrow in the illustration, resolves itself into components represented by the vertical and horizontal arrows. The lateral displacement, represented by the horizontal arrow is now determined. The counterweight is adjusted to locate the assembly center of gravity precisely, the assembly is freed to move in the gimbal, and the reaction engine is started. Because the true direction of thrust is laterally displaced, the reaction engine and vertical thrust member tend to rotate to the right. This is resisted by the mass of

the system exerted through the center of gravity so that a counterbalancing moment is eventually exerted and the system comes to rest at a certain angle from the perpendicular. By measuring this angle, the position is determined and by correlating system mass and engine thrust measurement, the true direction of the laterally displaced thrust is determined.

**Note:**

Inquiries concerning this invention may be directed to:

Technology Utilization Officer  
Jet Propulsion Laboratory  
4800 Oak Grove Drive  
Pasadena, California 91103  
Reference: B66-10642

**Patent status:**

Inquiries about obtaining rights for the commercial use of this invention may be made to NASA, Code GP, Washington, D.C. 20546.

Source: Herbert Shieber and Kirke Leonard  
of TRW Space Technology Laboratories  
under contract to  
Jet Propulsion Laboratory  
(JPL-SC-163)