

December 1966

Brief 66-10628

# NASA TECH BRIEF



NASA Tech Briefs are issued to summarize specific innovations derived from the U.S. space program, to encourage their commercial application. Copies are available to the public at 15 cents each from the Clearinghouse for Federal Scientific and Technical Information, Springfield, Virginia 22151.

## Controlled Release Device Prevents Damage from Dynamic Stresses

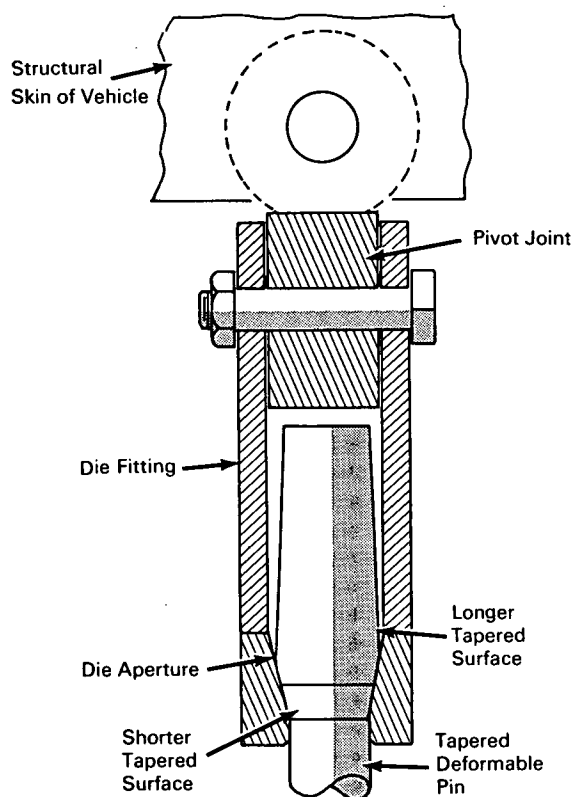

### The problem:

To develop a device that will control launch vehicle motion at liftoff. Vehicle liftoff from a launch pad or platform involves three steps: igniting the vehicle's first stage, restraining the vehicle with hold-down arms until the rocket engines attain full thrust, and releasing the vehicle by disengaging the hold-down arms. Instantaneous release of high thrust vehicles imparts a large transient load to the vehicle that can

rupture propellant tanks and damage the vehicle's structure and equipment.

### The solution:

A controlled release device that retards motion by extruding or drawing a tapered ductile pin through a die. The device prevents the damaging dynamic stresses that are imposed on the vehicle when it is instantaneously released at full thrust.

(continued overleaf)

**How it's done:**

The controlled release device consists of a pivot joint, die fitting, and tapered deformable pin. The pivot joint is linked to the die fitting and bolts to the structural skin at the base of the vehicle. The pin, made of ductile steel, has a cylindrical cross section. The double tapered segment of the pin fits within the die fitting; the straight shanked segment of the pin passes through the die's aperture and extends outside the fitting.

The aperture of the die is tapered with the small end facing outward. The shorter tapered surface of the pin seats against the aperture. Since the minor diameter of the aperture is smaller than the major diameter of the pin, the ductile pin will be deformed when it is pulled through the aperture. Resistance to movement diminishes as the pin is pulled through the die because the longer tapered surface of the pin has a decreasing diameter.

**Notes:**

1. Vehicle energy absorbed by the controlled release device is determined by pin diameter and by angles and lengths of the pin's tapered surfaces. The time required for complete passage of the pin through the die is determined by the length of the longer tapered surface. Thus, various pin configurations can be used to control release time and energy absorption.

2. While using a pin-and-die device to limit loads and absorb energy is new, this type device has been used for many years to draw or extrude wire from ductile pins. Because of this previous experience, the controlled release device is relatively easy to design. It is also easy and inexpensive to manufacture, reliable, and easily attached to the vehicle.
3. This device could be used as a fail-safe system for tension loads, a deceleration device for elevators, a shock absorber for space-vehicle landing gear, and other applications when it is desired to limit loads to specific values or to absorb given amounts of energy.
4. Inquiries concerning this invention may be directed to:

Technology Utilization Officer  
Kennedy Space Center  
Kennedy Space Center, Florida 32899  
Reference: B66-10628

**Patent status:**

Inquiries about obtaining rights for the commercial use of this invention may be made to NASA, Code GP, Washington, D.C. 20546.

Source: T. W. Burcham

(KSC-66-14)