

# NASA TECH BRIEF

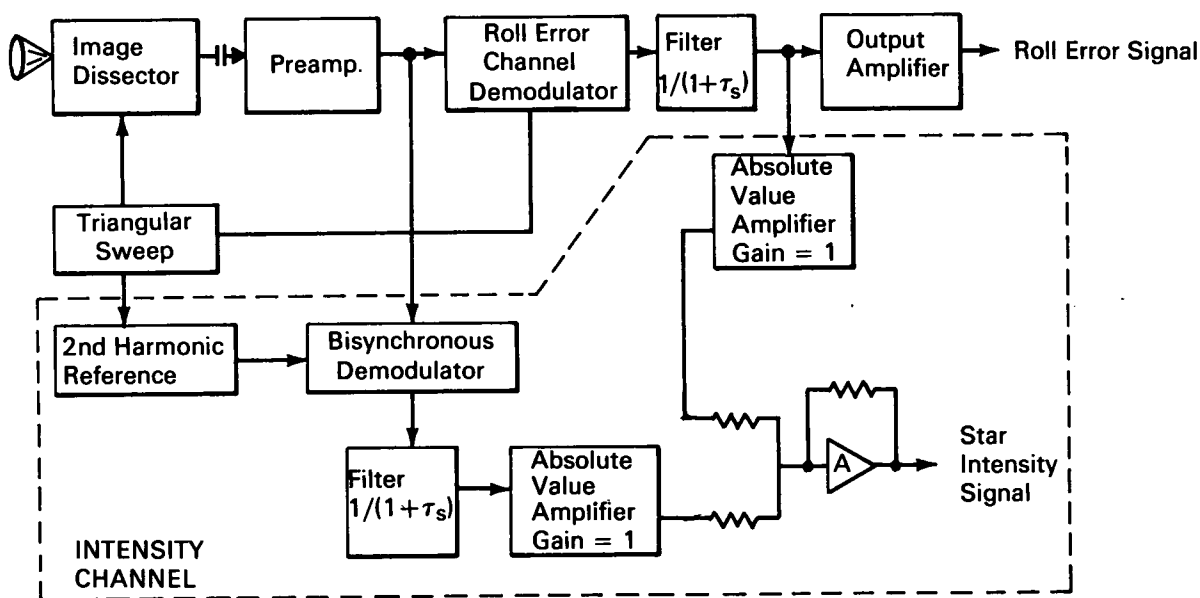

NASA Tech Briefs are issued to summarize specific innovations derived from the U. S. space program and to encourage their commercial application. Copies are available to the public from the Clearinghouse for Federal Scientific and Technical Information, Springfield, Virginia 22151.

## Point-Source Light Sensor Circuit Is Insensitive to Background Light



**The problem:**

To devise a circuit for an electro-optical star-tracking sensor that will provide a signal proportional to star intensity without interference from background light in the field of view. Conventional star sensors use a peak detector, which introduces a relatively large noise signal resulting from peak detection of the background light.

**The solution:**

A circuit incorporating a bisynchronous demodulator which extracts intensity information from the modulated signal in an electro-optical position sensor.

**How it's done:**

A thin slice of the sky, approximately 4 degrees by 32 degrees, is focused by an optical system upon

the photocathode of the image dissector. The electron space-charge analog of the optical image is transmitted toward an elongated vertical aperture at the far end of the image dissector. The electron analog is moved laterally in synchronism with a triangular sweep signal past this aperture. The output of the image dissector is then amplified in the preamplifier. The raw signal, as well as the sweep signal and the second harmonic reference, then goes to the two demodulators. Both demodulators are amplitude- and phase-sensitive, that is, have an output which varies depending on the amplitude and phase of the detected signal from the star with respect to the sweep voltage. The signal from the roll error channel demodulator, after being filtered and amplified, is the required roll error signal.

(continued overleaf)

Bisynchronous demodulation is utilized in the intensity channel. Basic to bisynchronous demodulation is the first harmonic reference signal, which has a frequency twice that of the sweep signal and a phase-shift lead of 90 degrees. The raw signal is demodulated and filtered as in the roll channel. The absolute values of the outputs from both demodulators are then summed to give a voltage which is exactly proportional to the average anode current and the star intensity, independent of the position of the star in the field of view.

**Notes:**

1. The system works best on a sharply focused star image and requires a 50 percent duty cycle.

2. This circuit can be advantageously used for extracting intensity information from any electro-optical position sensor or photometer where background noise presents a problem.
3. Inquiries concerning this invention may be directed to:

Technology Utilization Officer  
Jet Propulsion Laboratory  
4800 Oak Grove Drive  
Pasadena, California 91103  
Reference: B66-10502

**Patent status:**

Inquiries about obtaining rights for the commercial use of this invention may be made to NASA, Code GP, Washington, D.C. 20546.

Source: Edgar S. Davis  
(JPL-778)