

September 1966

Brief 66-10418

NASA TECH BRIEF



NASA Tech Briefs are issued to summarize specific innovations derived from the U. S. space program and to encourage their commercial application. Copies are available to the public from the Clearinghouse for Federal Scientific and Technical Information, Springfield, Virginia 22151.

Bearing Puller Facilitates Removal and Replacement of Bearing Assemblies

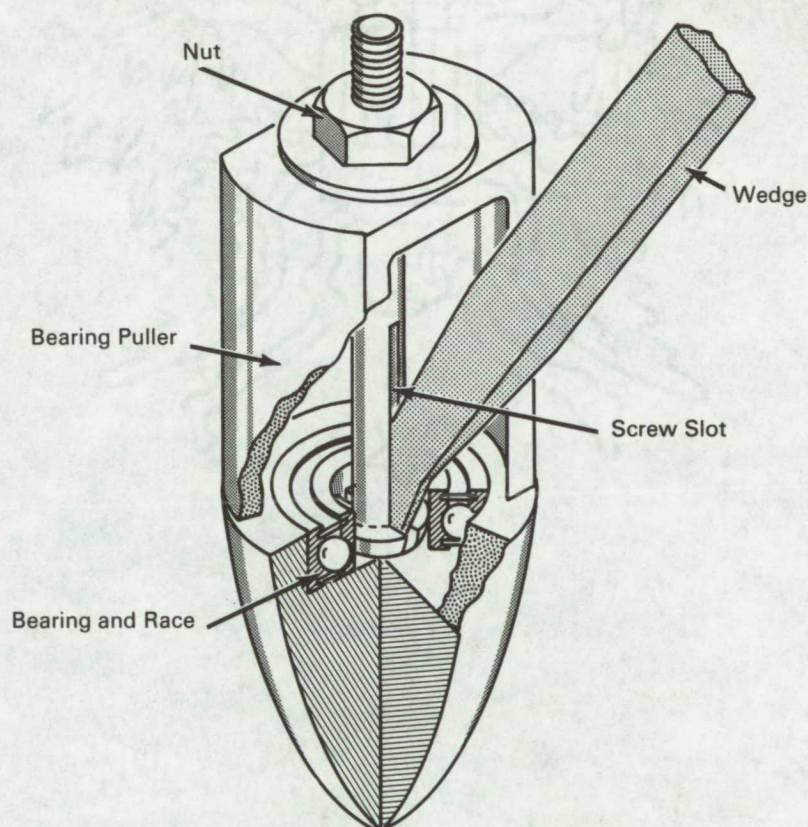

The problem:

To design a tool to remove ball bearing assemblies, which carry the rotor, from turbine type flowmeters. These bearings are usually semiconcealed and difficult to remove and replace. Returning the flowmeters to the manufacturer for bearing removal and replacement resulted in several weeks loss of use.

The solution:

A bearing puller which matches the bearing configuration to facilitate removal of bearing assemblies from the support members.

How it's done:

The head of the slotted screw is inserted in the inner race of the bearing to be removed. The wedge

(continued overleaf)

is inserted in the screw slot expanding the head to secure a firm grip on the bearing race. The sleeve, sized to clear the outer race of the bearing assembly, is positioned over the bearing assembly. The bearing is drawn into the sleeve by tightening the nut against the top of the sleeve.

Notes:

1. This tool has been found particularly useful in servicing highly specialized (one of a kind) flow-meters used in research and development programs.

2. Inquiries concerning this innovation may be directed to:

Technology Utilization Officer
Marshall Space Flight Center
Huntsville, Alabama 35812
Reference: B66-10418

Patent status:

No patent action is contemplated by NASA.

Source: R.B. Schaus
of North American Aviation, Inc.
under contract to
Marshall Space Flight Center
(M-FS-1538)