

August 1966

Brief 66-10384

# NASA TECH BRIEF



NASA Tech Briefs are issued to summarize specific innovations derived from the U. S. space program and to encourage their commercial application. Copies are available to the public from the Clearinghouse for Federal Scientific and Technical Information, Springfield, Virginia 22151.

## Universal Transloader Moves Delicate Equipment Without Stress

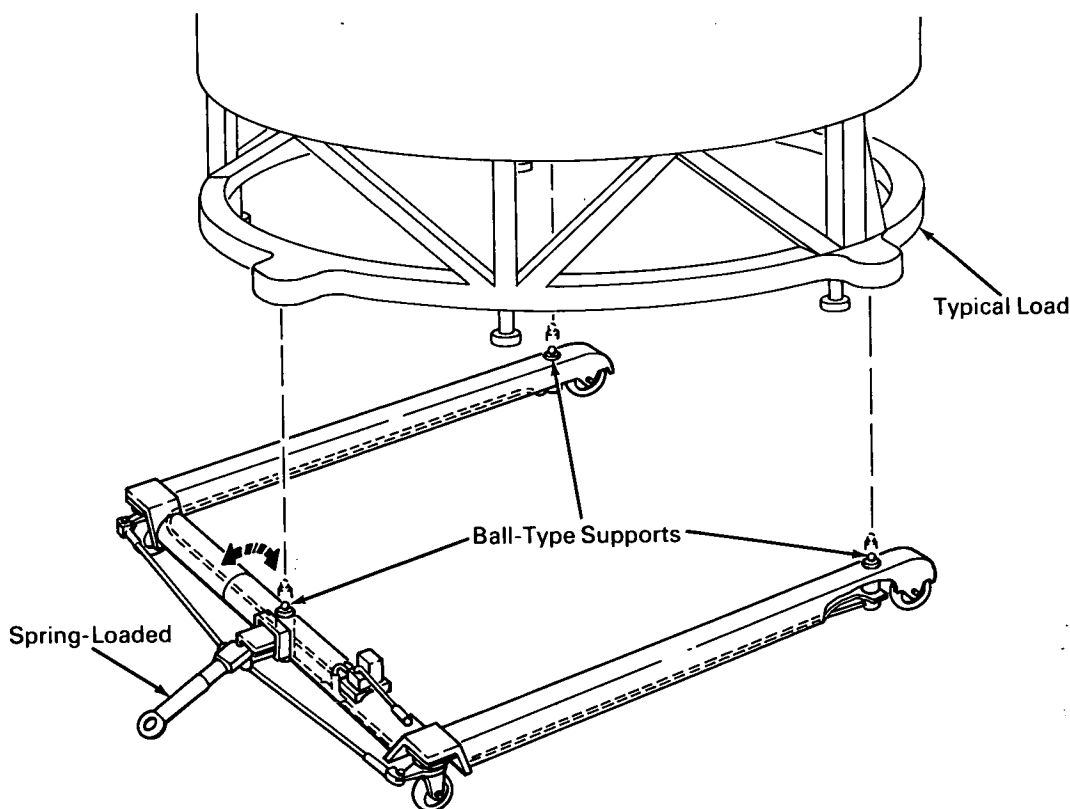

### The problem:

To move delicate or heavy items over irregular surfaces without transmitting stress to the load.

### The solution:

A loader that is supported on three pivot points to produce a warp-free base which in turn is supported by an articulated four-wheel frame.

### How it's done:

The transloader is supported by four widely spaced, evenly loaded wheels. Two of the wheels are located directly under support points. Transmission of distortion forces experienced by the transloader to the load's cradle is eliminated by the independent three-point support.

(continued overleaf)

One side member of the trailer is free to rotate about the longitudinal axis of the cross member to insure full wheel contact over uneven terrain and thus, an evenly distributed load. The motive power always provides a direct pull due to the universal joint connection to the cross member.

The support bases of the items to be moved are equipped with three extension arms which mate with the transloader pickup points. The transloader is maneuvered into position around the support base and the ball-socket extension arms are aligned with the three pick-up points. The supports are raised into position and the load is lifted for transporting. The vertical travel of the support points can be independent or synchronous and can be activated by mechanical, hydraulic, or electrical means.

Once the load has been moved to its new position it is set down by lowering the ball-type supports on

the transloader and moving the trailer out from under the item's cradle or base.

**Note:**

Inquiries concerning this invention may be directed to:

Technology Utilization Officer  
Manned Spacecraft Center  
Houston, Texas 77058  
Reference: B66-10384

**Patent status:**

Inquiries about obtaining rights for the commercial use of this invention may be made to NASA, Code GP, Washington, D.C. 20546.

Source: P. N. Kessler and J. R. Barbour  
of North American Aviation, Inc.  
under contract to  
Manned Spacecraft Center  
(MSC-654)