

July 1966

Brief 66-10342

NASA TECH BRIEF



NASA Tech Briefs are issued to summarize specific innovations derived from the U. S. space program and to encourage their commercial application. Copies are available to the public from the Clearinghouse for Federal Scientific and Technical Information, Springfield, Virginia 22151.

Gas Diffuser Facilitates Withdrawal of Cryogenic Liquids from Tanks

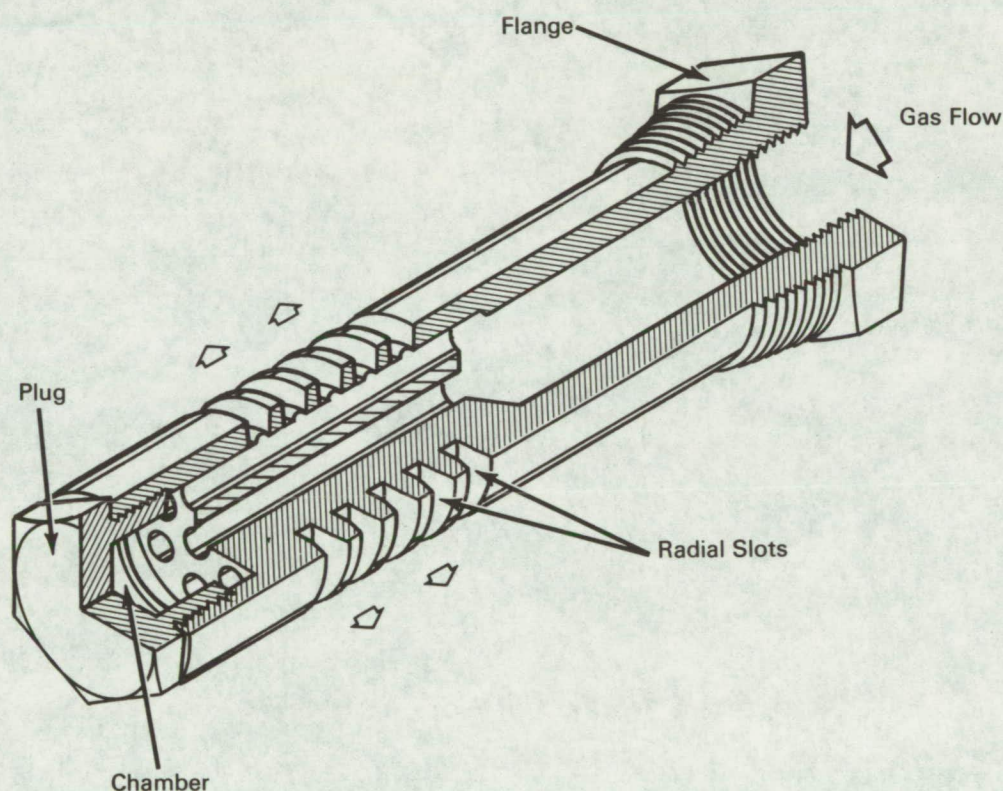

The problem:

To withdraw liquid oxygen from a tank, nitrogen gas is often fed through a diffuser into the vapor space above the surface of the liquid to maintain the necessary pressure for the desired withdrawal rate. A diffuser was required to minimize the loss of pressure that would result from the condensation or solution of large amounts of nitrogen gas in the liquid and to prevent direct impingement of the gas jets on the

liquid surface. Turbulence caused by direct impingement of the pressurizing gas entering the tank can introduce significant errors in measurements of the liquid level.

The solution:

A compact, cylindrical gas diffuser having radial exhaust slots and internal axial flow channels. This design provides efficient gas flow, a 50-percent open area, and the desired velocity profile.

(continued overleaf)

How it's done:

The diffuser, fabricated from stainless steel bar stock, is flanged to the gas line and concentrically located in the top of the tank. A center hole in the diffuser admits the gas into a small end chamber which facilitates gas flow distribution to several equally spaced axial holes. Radial slots machined through the diffuser wall direct the gas flow at 90 degrees to its axis, and thus parallel to the surface of the liquid in the tank.

Note:

Inquiries concerning this innovation may be directed to:

Technology Utilization Officer
Marshall Space Flight Center
Huntsville, Alabama 35812
Reference: B66-10342

Patent status:

No patent action is contemplated by NASA.

Source: J. D. Dunn
of North American Aviation, Inc.
under contract to
Marshall Space Flight Center
(MFS-915)