

July 1966

Brief 66-10326

NASA TECH BRIEF



NASA Tech Briefs are issued to summarize specific innovations derived from the U. S. space program and to encourage their commercial application. Copies are available to the public from the Clearinghouse for Federal Scientific and Technical Information, Springfield, Virginia 22151.

External Linkage Tie Permits Reduction in Ducting System Flange Thickness

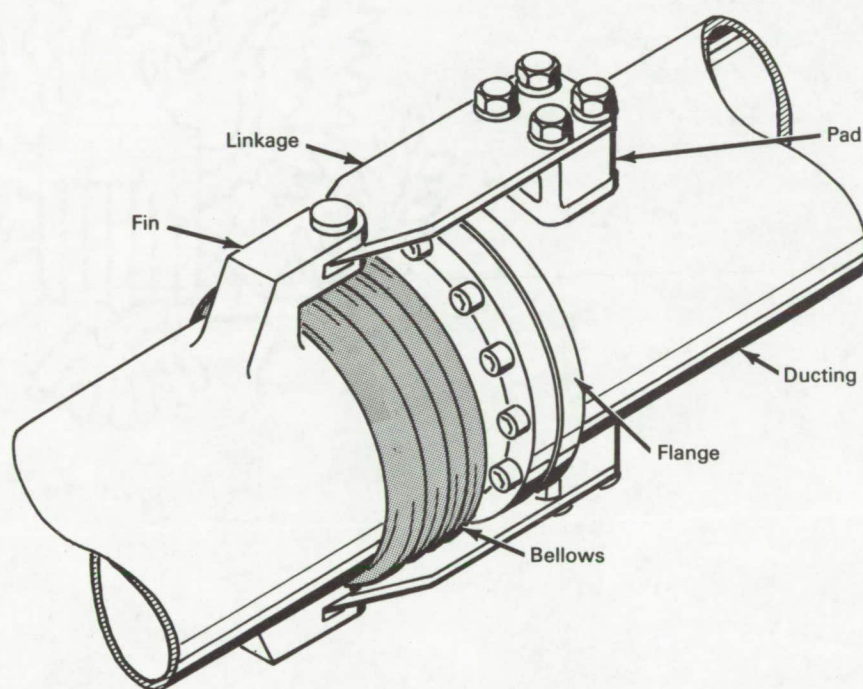

The problem:

In high pressure ducting and piping systems, where flanged joints and externally tied bellows are used, a method is required to reduce flange thickness and increase seal efficiency. Presently, the pressure separating load is transmitted directly to the flange, which has to be made extra thick to carry the load.

The solution:

An external linkage tie that will transmit the pressure separating load to the tube wall behind the flange.

How it's done:

The external linkage tie design concept may be accomplished by extending the linkage tie across the flange and bolting it to a pad directly behind the flanged joint. This would allow the flange to be designed to support only the seal, since the pressure separating load would be transmitted to the tube wall behind the flange.

This design will also permit the pressure load, caused by the bellows, to put the flanged joint in

(continued overleaf)

compression thereby increasing the efficiency of the seal.

Note:

Inquiries concerning this concept may be directed to:

Technology Utilization Officer
Marshall Space Flight Center
Huntsville, Alabama 35812
Reference: B66-10326

Patent status:

No patent action is contemplated by NASA.

Source: Robert O. Pflieger
of North American Aviation, Inc.
under contract to
Marshall Space Flight Center
(M-FS-823)